

ZUBEHÖR

FÜR WERKZEUGAUFNAHMEN

ACCESSORIES

FOR TOOL HOLDERS



INHALT CONTENT

Schrumpfverlängerungen / Shrink Fit Extensions

Schrumpfverlängerungen / Shrink Fit Extensions	728
Mini Shrink Verlängerungen / Mini Shrink Extensions	730
Heavy Duty Schrumpfverlängerungen / Heavy Duty Shrink Fit Extensions	731

Schrumpfspannzangen / Shrink Fit Collets

Schrumpfspannzangen ER11 / Shrink Fit Collets ER11	732
Schrumpfspannzangen ER16 / Shrink Fit Collets ER16	733
Schrumpfspannzangen ER20 / Shrink Fit Collets ER20	734
Schrumpfspannzangen ER25 / Shrink Fit Collets ER25	735
Schrumpfspannzangen ER32 / Shrink Fit Collets ER32	737

Spannzangen ER / Collets ER

Hochpräzisionsspannzangen ER / High Precision Collets ER	738
Hochpräzisionsspannzangen ER abgedichtet / High Precision Collets ER sealed	741
Hochpräzisionsspannzangen ER abgedichtet mit Cool Jet / High Precision Collets ER sealed with Cool Jet	743
Power Collet Spannzangen / Power Collets	744

Sonstiges Zubehör / Other Accessories

Torque Master Drehmomentschlüssel / Torque Master Torque Wrench	746
Einsätze für Torque Master / Inserts for Torque Master	746
Spannschlüssel / Wrenches	747
Rollenspannschlüssel für High Precision Collet Chucks / Roller Bearing Wrench for High Precision Collet Chucks	748
Glattmuttern für High Precision Collet Chucks / Smooth Locknuts for High Precision Collet Chucks	748
Spannmuttern für Spannzangenfutter / Locknuts for Collet Chucks	749
HG-Spannzangen und HG-Kegelwischer / HG Collets and HG Cone Wiper	750
HG Mini Verlängerungen / HG Mini Extensions	751
Anzugsbolzen / Pull Studs	753
Sägeblattaufnahmen / Sawblade Holders	756
Schrumpffutterbürsten, Kühlmittelrohre / Shrink Fit Brushes, Coolant Tubes	758
Reduzierhülsen / Reduction Sleeves	759
Auswuchtringe / Balancing Index Rings	762
Wuchtschraubensatz, Schwermetallwuchtschrauben / Set of Balancing Screws, Heavy Metal Balancing Screws	763
Einstellschrauben / Back Up Screws	764
Vorspannfedern für Schrumpffutter / Tension Springs for Shrink Fit Chuck	768
Spannschrauben / Clamping Screws	769
Schnellwechseleinsätze Typ FH / Quick Change Inserts Type FH	770
Messerkopf, Kombi-Zubehör / Accessories Face Mill, Combination Shell End Mill Adapter	771
Kegelwischer / Cone Wiper	772
Umrüstsatz DIN 2080-DIN 69871 / Conversion Kit DIN 2080-DIN 69871	775

SCHRUMPFVERLÄNGERUNGEN SHRINK FIT EXTENSIONS



Die universelle Lösung für Ihre Bearbeitungsfälle

- Absolute Rundlaufgenauigkeit
- Optimale und nahezu unbegrenzte Verlängerungen möglich
- Universell einsetzbar und immer wieder neu verwendbar
- Die wirtschaftlichere Art, Sonderteile zu bearbeiten
- Für HM- und HSS-Schäfte
- Lieferung ohne Kühladapter

The universal solution for your machining issues

- Highest runout accuracy
- Optimum and almost unlimited extensions likely
- Versatile to use and always re-usable
- The most economic way for special machining requirements
- For carbide steel and HSS shanks
- Delivery without cooling adapter

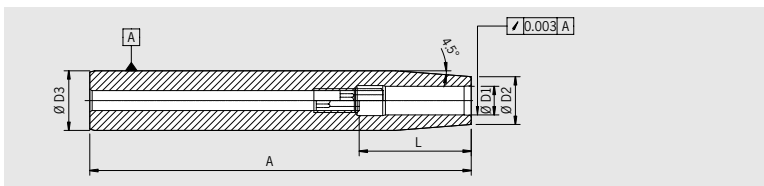

Ausführung:

- Mit Längeneinstellschraube (Verstellweg 10 mm)

Version:

- With set screw (adjustment range 10 mm)

Bestell-Nr. Order No.	L [mm]	Länge A Length A [mm]	Außen Ø Outer Ø D3 [mm]	Schafttoleranz Shank tolerance	Spann Ø Clamping Ø D1 [mm]	Ø D2 [mm]	Kühlung mit Kühlkörper Cooling body	zusätzlich benötigter Kühladapter/additional adapter required
78.160.06	28	160	16	h6	6	10	Ø 14-16	80.105.14.1.1
78.200.06	28	160	20	h6	6	14	Ø 14-16	80.105.14.1.2
78.200.08	34	160	20	h6	8	14	Ø 14-16	80.105.14.1.2
78.250.08	34	160	25	h6	8	19	Ø 6-8	—
78.250.10	42	160	25	h6	10	20	Ø 6-8	—
78.250.12	47	160	25	h6	12	20	Ø 6-8	—
78.250.14	47	160	25	h6	14	20	Ø 6-8	—
78.250.16	50	160	25	h6	16	22	Ø 6-8	—
78.320.10	42	160	32	h6	10	24	Ø 10-12	—
78.320.12	47	160	32	h6	12	24	Ø 10-12	—
78.320.14	47	160	32	h6	14	27	Ø 14-16	—
78.320.16	50	160	32	h6	16	27	Ø 14-16	—
78.320.18	50	160	32	h6	18	27	Ø 14-16	—
78.320.20	52	160	32	h6	20	27	Ø 14-16	—

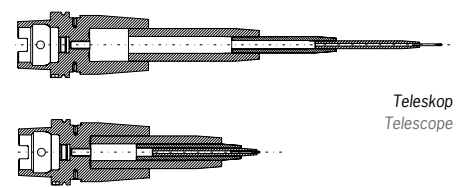
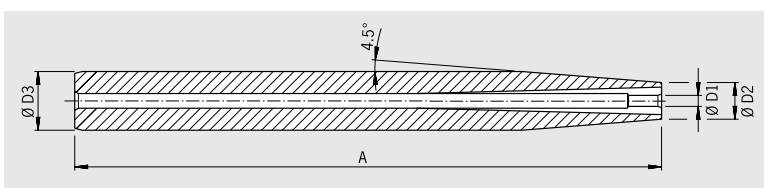

Teleskop
Telescope

Ausführung:

- Ohne Längeneinstellschraube
- Optimale Kühlmittelzuführung von außen durch Schlitz
- Beliebige Längeneinstellung (Teleskop)

Version:

- Without set screw
- With slits along the clamping bore for proper clamping and coolant around the cutting tool
- Variable length setting (telescope)

Bestell-Nr. Order No.	L [mm]	Länge A Length A [mm]	Außen Ø Outer Ø D3 [mm]	Schafttoleranz Shank tolerance	Spann Ø Clamping Ø D1 [mm]	Ø D2 [mm]	Kühlung mit Kühlkörper Cooling body	zusätzlich benötigter Kühladapter/additional adapter required
78.120.03.2	—	160	12	h6	3	8	Ø 14-16	80.105.14.1.1
78.120.04.2	—	160	12	h6	4	8	Ø 14-16	80.105.14.1.1
78.160.03.2	—	160	16	h6	3	10	Ø 14-16	80.105.14.1.1
78.160.04.2	—	160	16	h6	4	10	Ø 14-16	80.105.14.1.1
78.160.05.2	—	160	16	h6	5	10	Ø 14-16	80.105.14.1.1
78.200.05.2	—	160	20	h6	5	14	Ø 14-16	80.105.14.1.2

SCHRUMPFVERLÄNGERUNGEN

SHRINK FIT EXTENSIONS

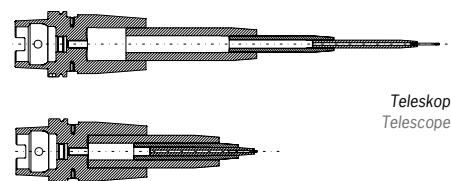
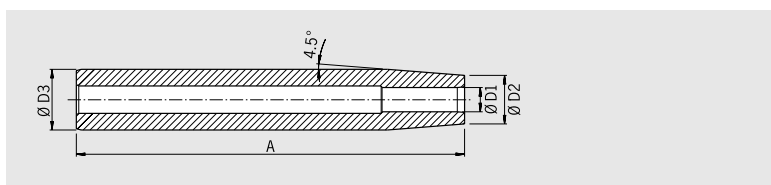

Teleskop
Telescope

Ausführung:

- Ohne Längeneinstellschraube
- Beliebige Längeneinstellung (Teleskop)

Version:

- Without set screw
- Variable length setting (telescope)

Bestell-Nr. Order No.	L [mm]	Länge A Length A [mm]	Außen Ø Outer Ø D3 [mm]	Schafttoleranz Shank tolerance	Spann Ø Clamping Ø D1 [mm]	Ø D2 [mm]	Kühlung mit Kühlkörper Cooling body	zusätzlich benötigter Kühladapter/additional adapter required
78.120.03.1	—	160	12	h4	3	8	Ø 14–16	80.105.14.1.1
78.120.04.1	—	160	12	h4	4	8	Ø 14–16	80.105.14.1.1
78.160.03.1	—	160	16	h4	3	10	Ø 14–16	80.105.14.1.1
78.160.04.1	—	160	16	h4	4	10	Ø 14–16	80.105.14.1.1
78.160.05.1	—	160	16	h4	5	10	Ø 14–16	80.105.14.1.1
78.160.06.1	—	160	16	h6	6	10	Ø 14–16	80.105.14.1.1
78.200.05.1	—	160	20	h4	5	14	Ø 14–16	80.105.14.1.2
78.200.06.1	—	160	20	h6	6	14	Ø 14–16	80.105.14.1.2
78.200.08.1	—	160	20	h6	8	14	Ø 14–16	80.105.14.1.2
78.250.08.1	—	160	25	h6	8	19	Ø 6–8	—
78.250.10.1	—	160	25	h6	10	20	Ø 6–8	—
78.250.12.1	—	160	25	h6	12	20	Ø 6–8	—
78.250.14.1	—	160	25	h6	14	20	Ø 6–8	—
78.250.16.1	—	160	25	h6	16	22	Ø 6–8	—
78.320.10.1	—	160	32	h6	10	24	Ø 10–12	—
78.320.12.1	—	160	32	h6	12	24	Ø 10–12	—
78.320.14.1	—	160	32	h6	14	27	Ø 14–16	—
78.320.16.1	—	160	32	h6	16	27	Ø 14–16	—
78.320.18.1	—	160	32	h6	18	27	Ø 14–16	—
78.320.20.1	—	160	32	h6	20	27	Ø 14–16	—

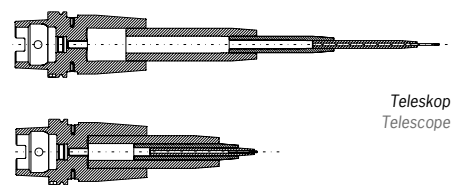
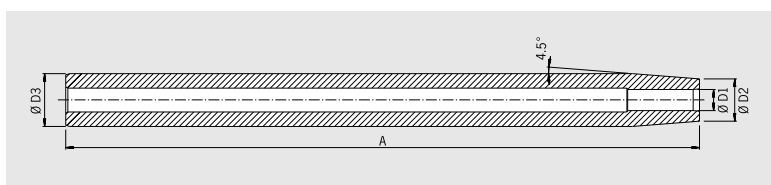

Teleskop
Telescope

Ausführung: 300 mm lang

- Ohne Längeneinstellschraube
- Beliebige Längeneinstellung (Teleskop)

Version: Extension length 300 mm

- Without set screw
- Variable length setting (telescope)

Bestell-Nr. Order No.	L [mm]	Länge A Length A [mm]	Außen Ø Outer Ø D3 [mm]	Schafttoleranz Shank tolerance	Spann Ø Clamping Ø D1 [mm]	Ø D2 [mm]	Kühlung mit Kühlkörper Cooling body	zusätzlich benötigter Kühladapter/additional adapter required
78.161.06.1	—	300	16	h6	6	10	Ø 14–16	80.105.14.1.1
78.201.06.1	—	300	20	h6	6	14	Ø 14–16	80.105.14.1.2
78.201.08.1	—	300	20	h6	8	14	Ø 14–16	80.105.14.1.2
78.251.08.1	—	300	25	h6	8	19	Ø 6–8	—
78.251.10.1	—	300	25	h6	10	20	Ø 6–8	—
78.251.12.1	—	300	25	h6	12	20	Ø 6–8	—
78.251.14.1	—	300	25	h6	14	20	Ø 6–8	—
78.251.16.1	—	300	25	h6	16	22	Ø 6–8	—
78.321.10.1	—	300	32	h6	10	24	Ø 10–12	—
78.321.12.1	—	300	32	h6	12	24	Ø 10–12	—
78.321.14.1	—	300	32	h6	14	27	Ø 14–16	—
78.321.16.1	—	300	32	h6	16	27	Ø 14–16	—
78.321.20.1	—	300	32	h6	20	27	Ø 14–16	—

SCHRUMPFVERLÄNGERUNGEN/SHRINK FIT EXTENSIONS MINI SHRINK VERLÄNGERUNGEN/MINI SHRINK EXTENSIONS

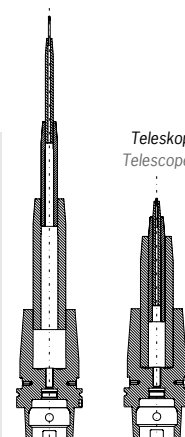
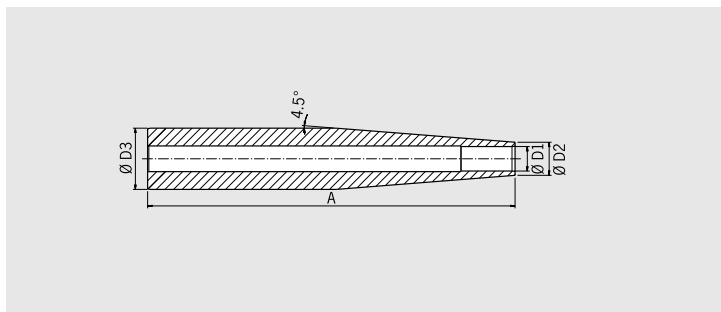

Ausführung: Verlängerung mit Außendurchmesser 50 mm
(Schrumpfen nur mit Power Clamp Profi Plus)

- HSS + HM

Version: Extension with diameter 50 mm
(Shrinking only with Power Clamp Profi Plus)

- HSS + solid carbide

Bestell-Nr. Order No.	L [mm]	Länge A Length A [mm]	Außen Ø Outer Ø D3 [mm]	Schafttoleranz Shank tolerance	Spann Ø Clamping Ø D1 [mm]	Ø D2 [mm]	Kühlung mit Kühlkörper Cooling body
78.501.10.1	—	300	50	h6	10	24	Ø 10-12
78.501.12.1	—	300	50	h6	12	24	Ø 10-12
78.501.14.1	—	300	50	h6	14	27	Ø 14-16
78.501.16.1	—	300	50	h6	16	27	Ø 14-16
78.501.18.1	—	300	50	h6	18	27	Ø 14-16
78.501.20.1	—	300	50	h6	20	33	Ø 18-20
78.501.25.1	—	300	50	h6	25	44	Ø 25-32
78.501.32.1	—	300	50	h6	32	44	Ø 25-32

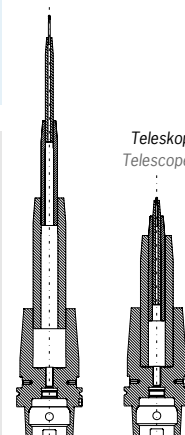
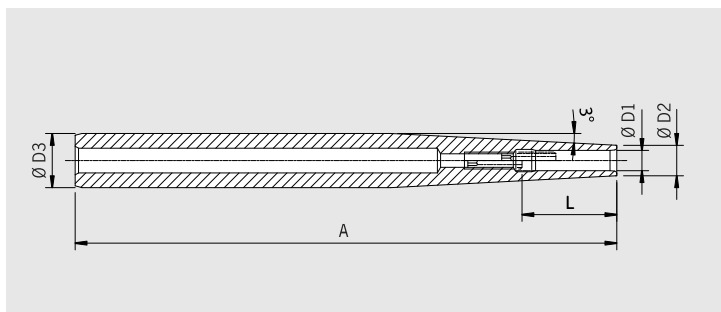

Mini Shrink Verlängerungen (Für alle HM-Werkzeuge mit Schaft-Toleranz h6)

Mini Shrink extensions (For all solid carbide tools with shank tolerance h6)

Standard Bestell-Nr. Order No.	L [mm]	Länge A Length A [mm]	Außen Ø Outer Ø D3 [mm]	Schafttoleranz Shank tolerance	Spann Ø Clamping Ø D1 [mm]	Ø D2 [mm]	Kühlung mit Kühlkörper Cooling body	passende Schrumpf- und Kühnhülse/suitable shrink and cooling sleeve
77.162.03	—	160	16	h6	3	9	Ø 6-8	80.105.14.2.04
77.162.04	—	160	16	h6	4	10	Ø 6-8	80.105.14.2.08
77.162.05	—	160	16	h6	5	11	Ø 6-8	80.105.14.2.05
77.162.06 ¹⁾	28	160	16	h6	6	12	Ø 6-8	80.105.14.2.09
77.162.08 ¹⁾	34	160	16	h6	8	14	Ø 6-8	80.105.14.2.10
77.162.10 ¹⁾	41	160	16	h6	10	16	Ø 6-8	—
77.202.06	—	200	20	h6	6	12	Ø 6-8	80.105.14.2.09
77.202.08	—	200	20	h6	8	14	Ø 6-8	80.105.14.2.10
77.202.10	—	200	20	h6	10	16	Ø 6-8	80.105.14.2.11
77.202.12	—	200	20	h6	12	18	Ø 6-8	80.105.14.2.12
Extra schlank/Extra slim								
77.160.03	—	160	16	h6	3	6	Ø 6-8	80.105.14.2.01
77.160.04	—	160	16	h6	4	7	Ø 6-8	80.105.14.2.02
77.160.05	—	160	16	h6	5	8	Ø 6-8	80.105.14.2.03
77.160.06 ¹⁾	28	160	16	h6	6	9	Ø 6-8	80.105.14.2.04
77.160.08 ¹⁾	34	160	16	h6	8	11	Ø 6-8	80.105.14.2.05
77.160.10 ¹⁾	41	160	16	h6	10	13	Ø 6-8	80.105.14.2.06
77.200.06	—	200	20	h6	6	9	Ø 6-8	80.105.14.2.04
77.200.08	—	200	20	h6	8	11	Ø 6-8	80.105.14.2.05
77.200.10	—	200	20	h6	10	13	Ø 6-8	80.105.14.2.06
77.200.12	—	200	20	h6	12	15	Ø 6-8	80.105.14.2.07

1) Mit Einstellschraube/With set screw

HEAVY DUTY SCHRUMPFVERLÄNGERUNGEN HEAVY DUTY SHRINK FIT EXTENSIONS

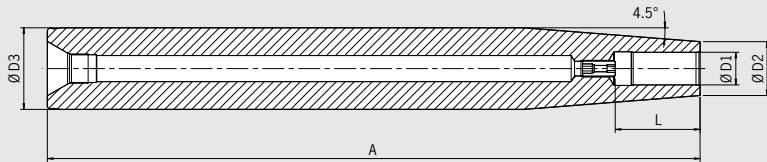

Heavy Duty Schrumpferlängerungen

- HAIMER als Systemanbieter: Die konsequente Ergänzung zu den Heavy Duty Chucks
- Extrem stabil mit 50 mm Außendurchmesser
- Sichere Abstützung des Werkzeuges mit Anschlagschrauben
- Schwerzerspannung auch in versteckten Winkeln: Länge 400 und 600 mm
- Bei Bedarf können die Verlängerungen auch gekürzt werden
- Auf Wunsch mit Hartmetalleinsatz zur Vibrationsdämpfung

Heavy Duty Shrink Fit Extensions

- HAIMER as full system provider: The consistent addition to the Heavy Duty Chucks
- Extremely stable with 50 mm outer diameter
- Safe support of the tool with set screws
- Heavy machining also in hidden angles: Lengths of 400 and 600 mm
- The extensions can be shortened to customer's needs on request
- Solid carbide inserts for vibration dampening on request

Heavy Duty Schrumpferlängerung ohne Hartmetallkern/Heavy Duty Shrink Fit Extensions without solid carbide core

Spann/Clamping	Ø D1 [mm]	16	20	25
	Ø D2 [mm]	27	33	44
	Ø D3 [mm]	50	50	50
	L [mm]	50	52	58
Maß/Length A [mm]	überlang/oversize	400	400	400
Bestell-Nr./Order No.	78.502...	.16	.20	.25
Maß/Length A [mm]	ZG600	600	600	600
Bestell-Nr./Order No.	78.506...	.16	.20	.25

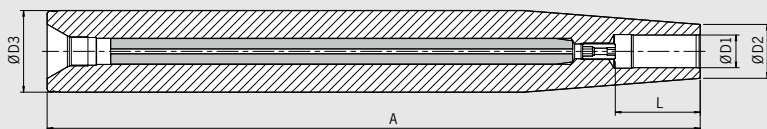

Heavy Duty Schrumpferlängerung mit Hartmetallkern/Heavy Duty Shrink Fit Extensions with solid carbide core

Spann/Clamping	Ø D1 [mm]	16	20	25
	Ø D2 [mm]	27	33	44
	Ø D3 [mm]	50	50	50
	L [mm]	50	52	58
Maß/Length A [mm]	überlang/oversize	400	400	400
Bestell-Nr./Order No.	78.502...	.16.9	.20.9	.25.9
Maß/Length A [mm]	ZG600	600	600	600
Bestell-Nr./Order No.	78.506...	.16.9	.20.9	.25.9

SCHRUMPFSPANNZANGEN ER11 (8°) SHRINK FIT COLLETS ER11 (8°)

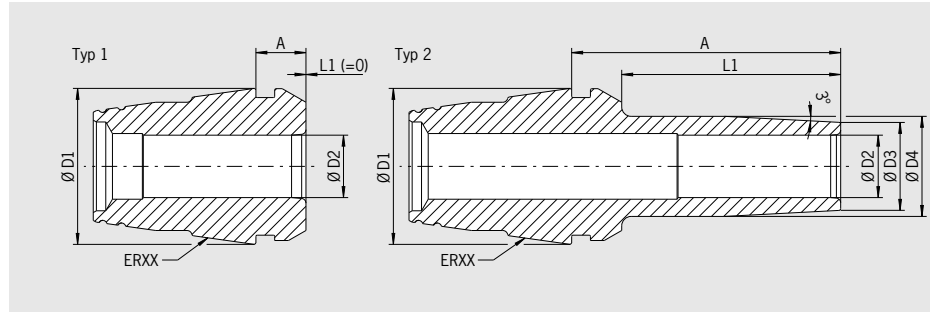

Ausführung

- Kompatibel mit allen gängigen Spannmuttern
- Optional mit Schlitz in der Spannbohrung für Kühlmittelzufuhr
- Für HM-Werkzeuge mit Schaft-Toleranz h6
- Nur schrumpfbar mit Power Clamp i4.0 Line und Handscanner

Version

- Compatible with all established ER nuts
- Optional with slits along the clamping bore for cooling from outside
- For solid carbide tools with shank tolerance h6
- Shrinking only possible with Power Clamp i4.0 line and hand scanner

Bestell-Nr. Order No.	Typ Type	ER Größe ER Size	D1 [mm]	A [mm]	L1 [mm]	D2 [mm]	D3 [mm]	D4 [mm]	Einstecktiefe Insertion depth [mm]
81.110.000.03	1	ER11	11	4,55	0	3	-	-	-
81.110.010.03	2	ER11	11	14,55	10	3	7	7,4	-
81.110.020.03	2	ER11	11	24,55	20	3	7	7,4	-
81.110.000.04	1	ER11	11	4,55	0	4	-	-	-
81.110.010.04	2	ER11	11	14,55	10	4	7	7,4	-
81.110.020.04	2	ER11	11	24,55	20	4	7	7,4	-
81.110.000.05 ¹⁾	1	ER11	11	4,55	0	5	-	-	-
81.110.000.06 ¹⁾	1	ER11	11	4,55	0	6	-	-	17

Kühlmittelschlitze/Coolant slots

Bestell-Nr./Order No. **91.100.42**

¹⁾ Anbringen von Schlitz nicht möglich
Mounting of slits not possible

SCHRUMPFSPANNZANGEN ER16 (8°) SHRINK FIT COLLETS ER16 (8°)

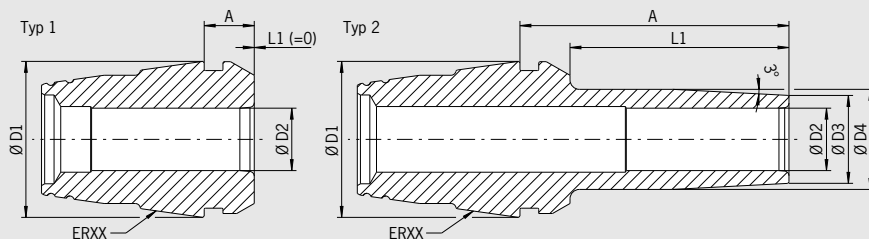

Ausführung

- Kompatibel mit allen gängigen Spannmuttern
- Optional mit Schlitzen in der Spannbohrung für Kühlmittelzufuhr
- Für HM-Werkzeuge mit Schaft-Toleranz h6
- Nur schrumpfbar mit Power Clamp i4.0 Line und Handscanner

Version

- Compatible with all established ER nuts
- Optional with slits along the clamping bore for cooling from outside
- For solid carbide tools with shank tolerance h6
- Shrinking only possible with Power Clamp i4.0 line and hand scanner

Bestell-Nr. Order No.	Typ Type	ER Größe ER Size	D1 [mm]	A [mm]	L1 [mm]	D2 [mm]	D3 [mm]	D4 [mm]	Einstecktiefe Insertion depth [mm]
81.160.000.03	1	ER16	16	6,7	0	3	–	–	–
81.160.010.03	2	ER16	16	16,7	10	3	7	–	–
81.160.020.03	2	ER16	16	26,7	20	3	7	–	–
81.160.025.03	2	ER16	16	31,7	25	3	7	–	–
81.160.030.03	2	ER16	16	36,7	30	3	7	9,5	–
81.160.035.03	2	ER16	16	41,7	35	3	7	9,5	–
81.160.000.04	1	ER16	16	6,7	0	4	–	–	–
81.160.010.04	2	ER16	16	16,7	10	4	7	–	–
81.160.020.04	2	ER16	16	26,7	20	4	7	–	–
81.160.025.04	2	ER16	16	31,7	25	4	7	–	–
81.160.030.04	2	ER16	16	36,7	30	4	7	9,5	–
81.160.035.04	2	ER16	16	41,7	35	4	7	9,5	–
81.160.000.05	1	ER16	16	6,7	0	5	–	–	–
81.160.010.05	2	ER16	16	16,7	10	5	8	–	–
81.160.020.05	2	ER16	16	26,7	20	5	8	9,5	–
81.160.025.05	2	ER16	16	31,7	25	5	8	9,5	–
81.160.030.05	2	ER16	16	36,7	30	5	8	9,5	–
81.160.035.05	2	ER16	16	41,7	35	5	8	9,5	–
81.160.000.06	1	ER16	16	6,7	0	6	–	–	–
81.160.010.06	2	ER16	16	16,7	10	6	9	–	–
81.160.020.06	2	ER16	16	26,7	20	6	9	10	–
81.160.025.06	2	ER16	16	31,7	25	6	9	10	–
81.160.030.06	2	ER16	16	36,7	30	6	9	10	–
81.160.035.06	2	ER16	16	41,7	35	6	9	10	–
81.160.000.08 ¹⁾	1	ER16	16	6,7	0	8	–	–	–
81.160.000.10 ¹⁾	1	ER16	16	6,7	0	10	–	–	23

Kühlmittelschlitze/Coolant slots

Bestell-Nr./Order No. **91.100.42**

1) Anbringen von Schlitzen nicht möglich
Mounting of slits not possible

SCHRUMPFSPANNZANGEN ER20 (8°) SHRINK FIT COLLETS ER20 (8°)

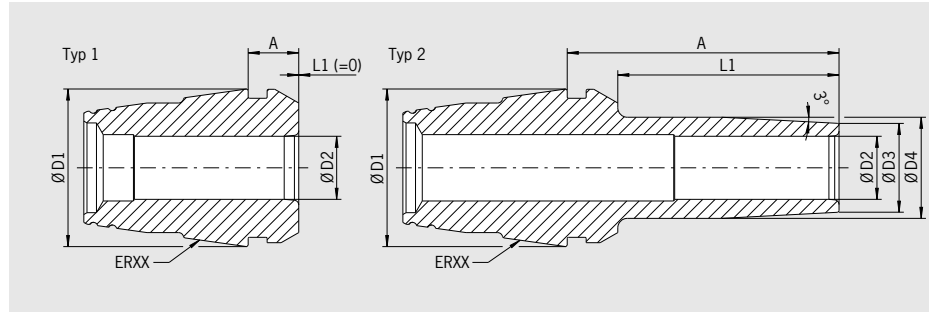

Ausführung

- Kompatibel mit allen gängigen Spannmuttern
- Optional mit Schlitz in der Spannbohrung für Kühlmittelzufuhr
- Für HM-Werkzeuge mit Schaft-Toleranz h6
- Nur schrumpfbar mit Power Clamp i4.0 Line und Handscanner

Version

- Compatible with all established ER nuts
- Optional with slits along the clamping bore for cooling from outside
- For solid carbide tools with shank tolerance h6
- Shrinking only possible with Power Clamp i4.0 line and hand scanner

Bestell-Nr. Order No.	Typ Type	ER Größe ER Size	D1 [mm]	A [mm]	L1 [mm]	D2 [mm]	D3 [mm]	D4 [mm]	Einstecktiefe Insertion depth [mm]
81.200.000.03	1	ER20	20	7,52	0	3	-	-	-
81.200.025.03	2	ER20	20	32,52	25	3	7	12,5	-
81.200.035.03	2	ER20	20	42,52	35	3	7	13,5	-
81.200.000.04	1	ER20	20	7,52	0	4	-	-	-
81.200.025.04	2	ER20	20	32,52	25	4	7	12,5	-
81.200.035.04	2	ER20	20	42,52	35	4	7	13,5	-
81.200.000.05	1	ER20	20	7,52	0	5	-	-	-
81.200.025.05	2	ER20	20	32,52	25	5	8	13,5	-
81.200.035.05	2	ER20	20	42,52	35	5	8	13,5	-
81.200.000.06	1	ER20	20	7,52	0	6	-	-	-
81.200.025.06	2	ER20	20	32,52	25	6	9	13,5	-
81.200.035.06	2	ER20	20	42,52	35	6	9	13,5	-
81.200.000.08	1	ER20	20	7,52	0	8	-	-	-
81.200.025.08	2	ER20	20	32,52	25	8	11	14	-
81.200.035.08	2	ER20	20	42,52	35	8	11	14	-
81.200.000.10	1	ER20	20	7,52	0	10	-	-	-
81.200.000.12 ¹⁾	1	ER20	20	7,52	0	12	-	-	29,5

Kühlmittelschlitze/Coolant slots

Bestell-Nr./Order No. **91.100.42**

1) Anbringen von Schlitz nicht möglich
Mounting of slits not possible

SCHRUMPFSPANNZANGEN ER25 (8°) SHRINK FIT COLLETS ER25 (8°)

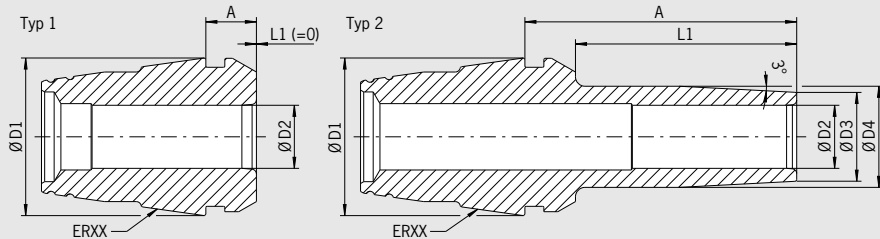

Ausführung

- Kompatibel mit allen gängigen Spannmütern
- Optional mit Schlitz in der Spannbohrung für Kühlmittelzufuhr
- Für HM-Werkzeuge mit Schaft-Toleranz h6
- Nur schrumpfbar mit Power Clamp i4.0 Line und Handscanner

Version

- Compatible with all established ER nuts
- Optional with slits along the clamping bore for cooling from outside
- For solid carbide tools with shank tolerance h6
- Shrinking only possible with Power Clamp i4.0 line and hand scanner

Bestell-Nr. Order No.	Typ Type	ER Größe ER Size	D1 [mm]	A [mm]	L1 [mm]	D2 [mm]	D3 [mm]	D4 [mm]	Einstecktiefe Insertion depth [mm]
81.250.000.03	1	ER25	25	8	0	3	-	-	-
81.250.010.03	2	ER25	25	18	10	3	7	12,5	-
81.250.020.03	2	ER25	25	28	20	3	7	12,5	-
81.250.025.03	2	ER25	25	33	25	3	7	12,5	-
81.250.030.03	2	ER25	25	38	30	3	7	13,5	-
81.250.035.03	2	ER25	25	43	35	3	7	13,5	-
81.250.000.04	1	ER25	25	8	0	4	-	-	-
81.250.010.04	2	ER25	25	18	10	4	7	12,5	-
81.250.020.04	2	ER25	25	28	20	4	7	12,5	-
81.250.025.04	2	ER25	25	33	25	4	7	12,5	-
81.250.030.04	2	ER25	25	38	30	4	7	13,5	-
81.250.035.04	2	ER25	25	43	35	4	7	13,5	-
81.250.000.05	1	ER25	25	8	0	5	-	-	-
81.250.010.05	2	ER25	25	18	10	5	8	13,5	-
81.250.020.05	2	ER25	25	28	20	5	8	13,5	-
81.250.025.05	2	ER25	25	33	25	5	8	13,5	-
81.250.030.05	2	ER25	25	38	30	5	8	14,5	-
81.250.035.05	2	ER25	25	43	35	5	8	14,5	-
81.250.000.06	1	ER25	25	8	0	6	-	-	-
81.250.010.06	2	ER25	25	18	10	6	9	14,5	-
81.250.020.06	2	ER25	25	28	20	6	9	14,5	-
81.250.025.06	2	ER25	25	33	25	6	9	14,5	-
81.250.030.06	2	ER25	25	38	30	6	9	15,5	-
81.250.035.06	2	ER25	25	43	35	6	9	15,5	-
81.250.000.08	1	ER25	25	8	0	8	-	-	-
81.250.010.08	2	ER25	25	18	10	8	11	16	-

Kühlmittelschlitze/Coolant slots

Bestell-Nr./Order No. 91.100.42

SCHRUMPFSPANNZANGEN ER25 (8°) SHRINK FIT COLLETS ER25 (8°)

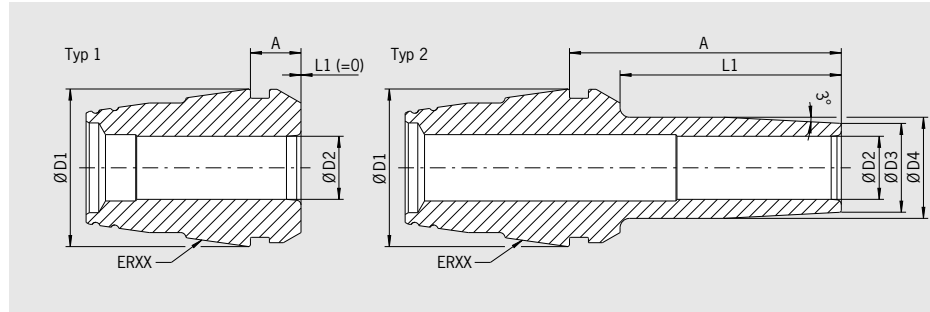

Ausführung

- Kompatibel mit allen gängigen Spannmuttern
- Optional mit Schlitz in der Spannbohrung für Kühlmittelzufuhr
- Für HM-Werkzeuge mit Schaft-Toleranz h6
- Nur schrumpfbar mit Power Clamp i4.0 Line und Handscanner

Version

- Compatible with all established ER nuts
- Optional with slits along the clamping bore for cooling from outside
- For solid carbide tools with shank tolerance h6
- Shrinking only possible with Power Clamp i4.0 line and hand scanner

Bestell-Nr. Order No.	Typ Type	ER Größe ER Size	D1 [mm]	A [mm]	L1 [mm]	D2 [mm]	D3 [mm]	D4 [mm]	Einstecktiefe Insertion depth [mm]
81.250.020.08	2	ER25	25	28	20	8	11	16	-
81.250.025.08	2	ER25	25	33	25	8	11	16	-
81.250.030.08	2	ER25	25	38	30	8	11	16,7	-
81.250.035.08	2	ER25	25	43	35	8	11	16,7	-
81.250.000.10	1	ER25	25	8	0	10	-	-	-
81.250.010.10	2	ER25	25	18	10	10	14	-	-
81.250.020.10	2	ER25	25	28	20	10	14	-	-
81.250.025.10	2	ER25	25	33	25	10	14	-	-
81.250.030.10	2	ER25	25	38	30	10	14	16	-
81.250.035.10	2	ER25	25	43	35	10	14	16	-
81.250.000.12	1	ER25	25	8	0	12	-	-	-
81.250.000.14	1	ER25	25	8	0	14	-	-	-
81.250.000.16 ¹⁾	1	ER25	25	8	0	16	-	-	33

Kühlmittelschlitze/Coolant slots

Bestell-Nr./Order No. **91.100.42**

1) Anbringen von Schlitz nicht möglich
Mounting of slits not possible

SCHRUMPFSPANNZANGEN ER32 (8°) SHRINK FIT COLLETS ER32 (8°)

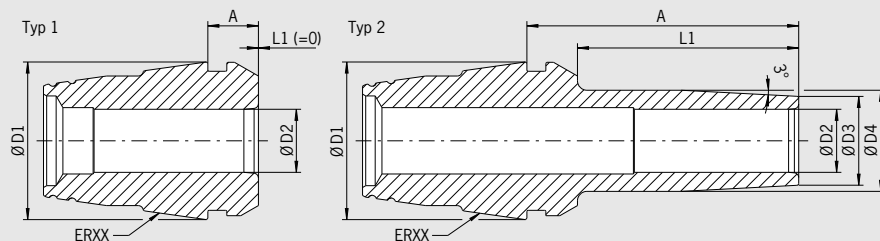

Ausführung

- Kompatibel mit allen gängigen Spannmuttern
- Optional mit Schlitz in der Spannbohrung für Kühlmittelzufuhr
- Für HM-Werkzeuge mit Schaft-Toleranz h6
- Nur schrumpfbar mit Power Clamp i4.0 Line und Handscanner

Version

- Compatible with all established ER nuts
- Optional with slits along the clamping bore for cooling from outside
- For solid carbide tools with shank tolerance h6
- Shrinking only possible with Power Clamp i4.0 line and hand scanner

Bestell-Nr. Order No.	Typ Type	ER Größe ER Size	D1 [mm]	A [mm]	L1 [mm]	D2 [mm]	D3 [mm]	D4 [mm]	Einstecktiefe Insertion depth [mm]
81.320.000.03	1	ER32	32	9	0	3	–	–	–
81.320.035.03	2	ER32	32	44	35	3	7	15	–
81.320.000.04	1	ER32	32	9	0	4	–	–	–
81.320.035.04	2	ER32	32	44	35	4	7	15	–
81.320.000.05	1	ER32	32	9	0	5	–	–	–
81.320.035.05	2	ER32	32	44	35	5	8	16	–
81.320.000.06	1	ER32	32	9	0	6	–	–	–
81.320.035.06	2	ER32	32	44	35	6	9	17	–
81.320.000.08	1	ER32	32	9	0	8	–	–	–
81.320.035.08	2	ER32	32	44	35	8	11	19	–
81.320.000.10	1	ER32	32	9	0	10	–	–	–
81.320.035.10	2	ER32	32	44	35	10	14	22	–
81.320.000.12	1	ER32	32	9	0	12	–	–	–
81.320.035.12	2	ER32	32	44	35	12	15	24	–
81.320.000.14	1	ER32	32	9	0	14	–	–	–
81.320.035.14	2	ER32	32	44	35	14	17	24	–
81.320.000.16	1	ER32	32	9	0	16	–	–	–
81.320.035.16	2	ER32	32	44	35	16	19	24	–
81.320.000.18	1	ER32	32	9	0	18	–	–	–
81.320.000.20	1	ER32	32	9	0	20	–	–	–

Kühlmittelslitze/Coolant slots

Bestell-Nr./Order No. **91.100.42**

HOCHPRÄZISIONSSPANNZANGEN ER HIGH PRECISION COLLETS ER

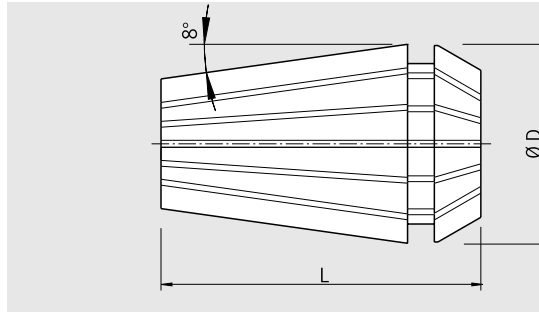

- Polierte Oberfläche garantiert Präzision und Langlebigkeit, insbesondere unter Verwendung von HAIMER ER Spannanzangenfutter
- ISO 15488 (früher DIN 6499)
- Überlegene Haltekräfte
- Passend für ER-Spannzangenfutter aller Hersteller
- Rundlaufgenauigkeit 5 µm

- High polished finish for extra accuracy and long life, especially when clamped in HAIMER ER collet chucks
- ISO 15488 (previously DIN 6499)
- Superior clamping strength
- Fits all brands of ER collet holders
- Run-out accuracy 5 µm

Bestell-Nr. Order No.	ER Größe ER Size	[mm]	D [mm]	L [mm]
81.110.1.0	ER11	0.50 – 1.00	11,5	18
81.110.1.5	ER11	1.00 – 1.50	11,5	18
81.110.2.0	ER11	1.50 – 2.00	11,5	18
81.110.2.5	ER11	2.00 – 2.50	11,5	18
81.110.3.0	ER11	2.50 – 3.00	11,5	18
81.110.3.5	ER11	3.00 – 3.50	11,5	18
81.110.4.0	ER11	3.50 – 4.00	11,5	18
81.110.4.5	ER11	4.00 – 4.50	11,5	18
81.110.5.0	ER11	4.50 – 5.00	11,5	18
81.110.5.5	ER11	5.00 – 5.50	11,5	18
81.110.6.0	ER11	5.50 – 6.00	11,5	18
81.110.6.5	ER11	6.00 – 6.50	11,5	18
81.110.7.0	ER11	6.50 – 7.00	11,5	18
81.110.00	ER11	Spannzangensatz (7 Stk., einzeln verpackt) Set of ER collets (7 pcs., seperatly packaged)		

Bestell-Nr. Order No.	ER Größe ER Size	[mm]	D [mm]	L [mm]
81.160.01	ER16	0.50 – 1.00	17	27
81.160.1.5	ER16	1.00 – 1.50	17	27
81.160.02	ER16	1.50 – 2.00	17	27
81.160.2.5	ER16	2.00 – 2.50	17	27
81.160.03	ER16	2.00 – 3.00	17	27
81.160.04	ER16	3.00 – 4.00	17	27
81.160.05	ER16	4.00 – 5.00	17	27
81.160.06	ER16	5.00 – 6.00	17	27
81.160.07	ER16	6.00 – 7.00	17	27
81.160.08	ER16	7.00 – 8.00	17	27
81.160.09	ER16	8.00 – 9.00	17	27
81.160.10	ER16	9.00 – 10.00	17	27
81.160.00	ER16	Spannzangensatz (10 Stk., einzeln verpackt) Set of ER collets (10 pcs., seperatly packaged)		
81.160.001	ER16	Spannzangensatz (10 Stk., auf Werkzeugträger) Set of ER collets (10 pcs., with collet carrier)		

HOCHPRÄZISIONSSPANNZANGEN ER

HIGH PRECISION COLLETS ER

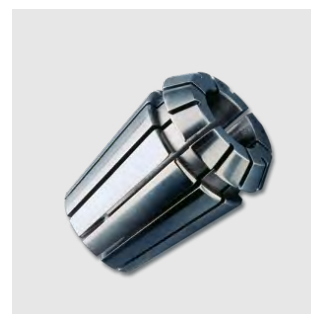
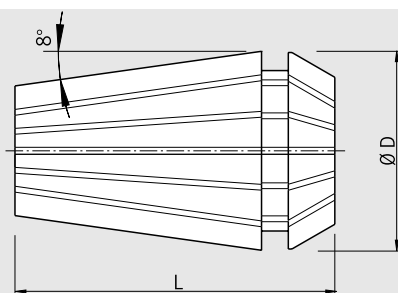

- Polierte Oberfläche garantiert Präzision und Langlebigkeit, insbesondere unter Verwendung von HAIMER ER Spannzangenfutter
- ISO 15488 (früher DIN 6499)
- Überlegene Haltekräfte
- Passend für ER-Spannzangenfutter aller Hersteller
- Rundlaufgenauigkeit 5 µm

- High polished finish for extra accuracy and long life, especially when clamped in HAIMER ER collet chucks
- ISO 15488 (previously DIN 6499)
- Superior clamping strength
- Fits all brands of ER collet holders
- Run-out accuracy 5 µm

Bestell-Nr. Order No.	ER Größe ER Size	[mm]	D [mm]	L [mm]
81.200.02	ER20	1.50 – 2.00	21	31,5
81.200.03	ER20	2.00 – 3.00	21	31,5
81.200.04	ER20	3.00 – 4.00	21	31,5
81.200.05	ER20	4.00 – 5.00	21	31,5
81.200.06	ER20	5.00 – 6.00	21	31,5
81.200.07	ER20	6.00 – 7.00	21	31,5
81.200.08	ER20	7.00 – 8.00	21	31,5
81.200.09	ER20	8.00 – 9.00	21	31,5
81.200.10	ER20	9.00 – 10.00	21	31,5
81.200.11	ER20	10.00 – 11.00	21	31,5
81.200.12	ER20	11.00 – 12.00	21	31,5
81.200.13	ER20	12.00 – 13.00	21	31,5
81.200.00	ER20	Spannzangensatz (12 Stk., einzeln verpackt) Set of ER collets (12 pcs., seperatly packaged)		
81.200.001	ER20	Spannzangensatz (12 Stk., auf Werkzeugträger) Set of ER collets (12 pcs., with collet carrier)		

Bestell-Nr. Order No.	ER Größe ER Size	[mm]	D [mm]	L [mm]
81.250.1.5	ER25	1.00 – 1.50	26	35
81.250.02	ER25	1.50 – 2.00	26	35
81.250.2.5	ER25	1.50 – 2.50	26	35
81.250.03	ER25	2.00 – 3.00	26	35
81.250.04	ER25	3.00 – 4.00	26	35
81.250.05	ER25	4.00 – 5.00	26	35
81.250.06	ER25	5.00 – 6.00	26	35
81.250.07	ER25	6.00 – 7.00	26	35
81.250.08	ER25	7.00 – 8.00	26	35
81.250.09	ER25	8.00 – 9.00	26	35
81.250.10	ER25	9.00 – 10.00	26	35
81.250.11	ER25	10.00 – 11.00	26	35
81.250.12	ER25	11.00 – 12.00	26	35
81.250.13	ER25	12.00 – 13.00	26	35
81.250.14	ER25	13.00 – 14.00	26	35
81.250.15	ER25	14.00 – 15.00	26	35
81.250.16	ER25	15.00 – 16.00	26	35
81.250.00	ER25	Spannzangensatz (15 Stk., einzeln verpackt) Set of ER collets (15 pcs., seperatly packaged)		
81.250.001	ER25	Spannzangensatz (15 Stk., auf Werkzeugträger) Set of ER collets (15 pcs., with collet carrier)		

HOCHPRÄZISIONSSPANNZANGEN ER HIGH PRECISION COLLETS ER

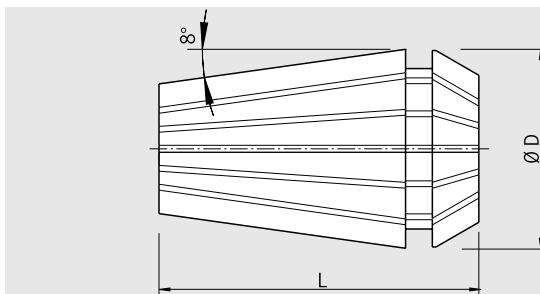

- Polierte Oberfläche garantiert Präzision und Langlebigkeit, insbesondere unter Verwendung von HAIMER ER Spannzangenfutter
- ISO 15488 (früher DIN 6499)
- Überlegene Haltekräfte
- Passend für ER-Spannzangenfutter aller Hersteller
- Rundlaufgenauigkeit 5 µm

- High polished finish for extra accuracy and long life, especially when clamped in HAIMER ER collet chucks
- ISO 15488 (previously DIN 6499)
- Superior clamping strength
- Fits all brands of ER collet holders
- Run-out accuracy 5 µm

Bestell-Nr. Order No.	ER Größe ER Size	[mm]	D [mm]	L [mm]
81.320.02	ER32	1.50 – 2.00	33	40
81.320.2.5	ER32	1.50 – 2.50	33	40
81.320.03	ER32	2.00 – 3.00	33	40
81.320.04	ER32	3.00 – 4.00	33	40
81.320.05	ER32	4.00 – 5.00	33	40
81.320.06	ER32	5.00 – 6.00	33	40
81.320.07	ER32	6.00 – 7.00	33	40
81.320.08	ER32	7.00 – 8.00	33	40
81.320.09	ER32	8.00 – 9.00	33	40
81.320.10	ER32	9.00 – 10.00	33	40
81.320.11	ER32	10.00 – 11.00	33	40
81.320.12	ER32	11.00 – 12.00	33	40
81.320.13	ER32	12.00 – 13.00	33	40
81.320.14	ER32	13.00 – 14.00	33	40
81.320.15	ER32	14.00 – 15.00	33	40
81.320.16	ER32	15.00 – 16.00	33	40
81.320.17	ER32	16.00 – 17.00	33	40
81.320.18	ER32	17.00 – 18.00	33	40
81.320.19	ER32	18.00 – 19.00	33	40
81.320.20	ER32	19.00 – 20.00	33	40
81.320.00	ER32	Spannzangensatz (19 Stk., einzeln verpackt) Set of ER collets (19 pcs., seperatly packaged)		
81.320.001	ER32	Spannzangensatz (19 Stk., auf Werkzeugträger) Set of ER collets (19 pcs., with collet carrier)		

Bestell-Nr. Order No.	ER Größe ER Size	[mm]	D [mm]	L [mm]
81.400.03	ER40	2.50 – 3.00	41	46
81.400.04	ER40	3.00 – 4.00	41	46
81.400.05	ER40	4.00 – 5.00	41	46
81.400.06	ER40	5.00 – 6.00	41	46
81.400.07	ER40	6.00 – 7.00	41	46
81.400.08	ER40	7.00 – 8.00	41	46
81.400.09	ER40	8.00 – 9.00	41	46
81.400.10	ER40	9.00 – 10.00	41	46
81.400.11	ER40	10.00 – 11.00	41	46
81.400.12	ER40	11.00 – 12.00	41	46
81.400.13	ER40	12.00 – 13.00	41	46
81.400.14	ER40	13.00 – 14.00	41	46
81.400.15	ER40	14.00 – 15.00	41	46
81.400.16	ER40	15.00 – 16.00	41	46
81.400.17	ER40	16.00 – 17.00	41	46
81.400.18	ER40	17.00 – 18.00	41	46
81.400.19	ER40	18.00 – 19.00	41	46
81.400.20	ER40	19.00 – 20.00	41	46
81.400.21	ER40	20.00 – 21.00	41	46
81.400.22	ER40	21.00 – 22.00	41	46
81.400.23	ER40	22.00 – 23.00	41	46
81.400.24	ER40	23.00 – 24.00	41	46
81.400.25	ER40	24.00 – 25.00	41	46
81.400.26	ER40	25.00 – 26.00	41	46
81.400.00	ER40	Spannzangensatz (24 Stk., einzeln verpackt) Set of ER collets (24 pcs., seperatly packaged)		
81.400.001	ER40	Spannzangensatz (24 Stk., auf Werkzeugträger) Set of ER collets (24 pcs., with collet carrier)		

HOCHPRÄZISIONSSPANNZANGEN ER – ABGEDICHTET

HIGH PRECISION COLLETS ER – SEALED

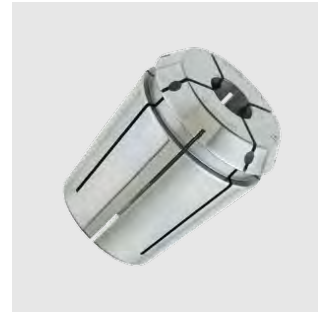
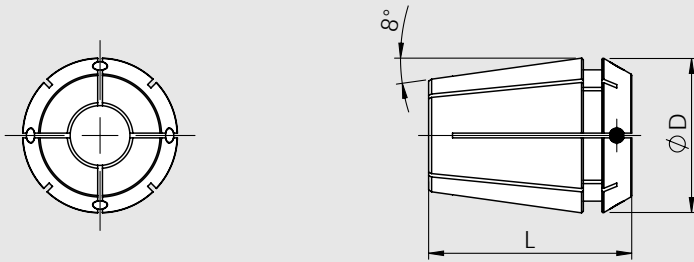

- Polierte Oberfläche garantiert Präzision und Langlebigkeit, insbesondere unter Verwendung von HAIMER ER Spannzangenfutter
- ISO 15488 (früher DIN 6499)
- Überlegene Haltekräfte
- Passend für ER-Spannzangenfutter aller Hersteller
- Rundlaufgenauigkeit 5 µm
- Mit Abdichtung für Innenkühlung

- High polished finish for extra accuracy and long life, especially when clamped in HAIMER ER collet chucks
- ISO 15488 (previously DIN 6499)
- Superior clamping strength
- Fits all brands of ER collet holders
- Run-out accuracy 5 µm
- Sealed for internal coolant tools

Bestell-Nr. Order No.	ER Größe ER Size	[mm]	D [mm]	L [mm]
81.165.03	ER16	03	16,70	30
81.165.04	ER16	04	16,70	30
81.165.05	ER16	05	16,70	30
81.165.06	ER16	06	16,70	30
81.165.07	ER16	07	16,70	30
81.165.08	ER16	08	16,70	30
81.165.09	ER16	09	16,70	30
81.165.10	ER16	10	16,70	30

Bestell-Nr. Order No.	ER Größe ER Size	[mm]	D [mm]	L [mm]
81.205.03	ER20	03	20,70	30
81.205.04	ER20	04	20,70	30
81.205.05	ER20	05	20,70	30
81.205.06	ER20	06	20,70	30
81.205.07	ER20	07	20,70	30
81.205.08	ER20	08	20,70	30
81.205.09	ER20	09	20,70	30
81.205.10	ER20	10	20,70	30
81.205.11	ER20	11	20,70	30
81.205.12	ER20	12	20,70	30

Bestell-Nr. Order No.	ER Größe ER Size	[mm]	D [mm]	L [mm]
81.255.03	ER25	03	25,70	34
81.255.04	ER25	04	25,70	34
81.255.05	ER25	05	25,70	34
81.255.06	ER25	06	25,70	34
81.255.07	ER25	07	25,70	34
81.255.08	ER25	08	25,70	34
81.255.09	ER25	09	25,70	34
81.255.10	ER25	10	25,70	34
81.255.11	ER25	11	25,70	34
81.255.12	ER25	12	25,70	34
81.255.13	ER25	13	25,70	34
81.255.14	ER25	14	25,70	34
81.255.15	ER25	15	25,70	34
81.255.16	ER25	16	25,70	34

HOCHPRÄZISIONSSPANNZANGEN ER – ABGEDICHTET HIGH PRECISION COLLETS ER – SEALED

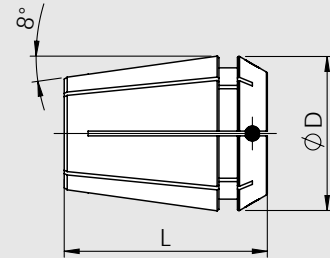
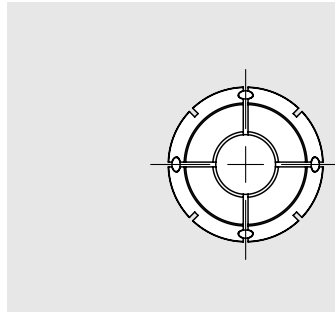

- Polierte Oberfläche garantiert Präzision und Langlebigkeit, insbesondere unter Verwendung von HAIMER ER Spannzangenfutter
- ISO 15488 (früher DIN 6499)
- Überlegene Haltekräfte
- Passend für ER-Spannzangenfutter aller Hersteller
- Rundlaufgenauigkeit 5 µm
- Mit Abdichtung für Innenkühlung

- High polished finish for extra accuracy and long life, especially when clamped in HAIMER ER collet chucks
- ISO 15488 (previously DIN 6499)
- Superior clamping strength
- Fits all brands of ER collet holders
- Run-out accuracy 5 µm
- Sealed for internal coolant tools

Bestell-Nr. Order No.	ER Größe ER Size	[mm]	D [mm]	L [mm]
81.325.03	ER32	03	32,70	45
81.325.04	ER32	04	32,70	45
81.325.05	ER32	05	32,70	45
81.325.06	ER32	06	32,70	45
81.325.07	ER32	07	32,70	45
81.325.08	ER32	08	32,70	45
81.325.09	ER32	09	32,70	45
81.325.10	ER32	10	32,70	45
81.325.11	ER32	11	32,70	45
81.325.12	ER32	12	32,70	45
81.325.13	ER32	13	32,70	45
81.325.14	ER32	14	32,70	45
81.325.15	ER32	15	32,70	45
81.325.16	ER32	16	32,70	45
81.325.17	ER32	17	32,70	45
81.325.18	ER32	18	32,70	45
81.325.19	ER32	19	32,70	45
81.325.20	ER32	20	32,70	45

Bestell-Nr. Order No.	ER Größe ER Size	[mm]	D [mm]	L [mm]
81.405.06	ER40	06	40,70	30
81.405.08	ER40	08	40,70	30
81.405.10	ER40	10	40,70	30
81.405.12	ER40	12	40,70	30
81.405.14	ER40	14	40,70	30
81.405.16	ER40	16	40,70	30
81.405.18	ER40	18	40,70	30
81.405.20	ER40	20	40,70	30
81.405.22	ER40	22	40,70	30
81.405.25	ER40	25	40,70	30

HOCHPRÄZISIONSSPANNZANGEN ER – ABGEDICHTET MIT COOL JET HIGH PRECISION COLLETS ER – SEALED WITH COOL JET

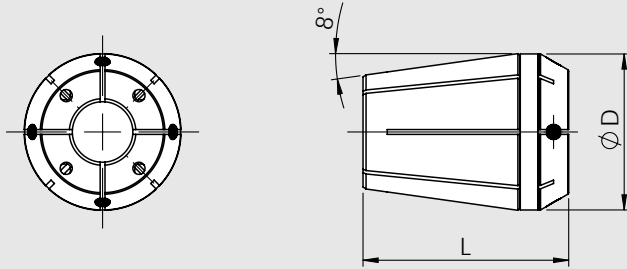

- Polierte Oberfläche garantiert Präzision und Langlebigkeit, insbesondere unter Verwendung von HAIMER ER Spannzangenfutter
- ISO 15488 (früher DIN 6499)
- Überlegene Haltekräfte
- Passend für ER-Spannzangenfutter aller Hersteller
- Rundlaufgenauigkeit 3 µm
- Mit Cool Jet Bohrungen für optimale Kühlmittelzufuhr
- Für zylindrische Schäfte h8 oder besser

- High polished finish for extra accuracy and long life, especially when clamped in HAIMER ER collet chucks
- ISO 15488 (previously DIN 6499)
- Superior clamping strength
- Fits all brands of ER collet holders
- Run-out accuracy 3 µm
- With Cool Jet bores for optimal coolant supply
- For cylindrical shanks with tolerance h8 or better

Bestell-Nr. Order No.	ER Größe ER Size	[mm]	D [mm]	L [mm]
81.252.04	ER25	04	26	34
81.252.06	ER25	06	26	34
81.252.08	ER25	08	26	34
81.252.10	ER25	10	26	34
81.252.12	ER25	12	26	34
81.252.14	ER25	14	26	34

Bestell-Nr. Order No.	ER Größe ER Size	[mm]	D [mm]	L [mm]
81.322.04	ER32	04	33	45
81.322.06	ER32	06	33	45
81.322.08	ER32	08	33	45
81.322.10	ER32	10	33	45
81.322.12	ER32	12	33	45
81.322.14	ER32	14	33	45
81.322.16	ER32	16	33	45
81.322.18	ER32	18	33	45
81.322.20	ER32	20	33	45

Achtung: Der blaue Ring dient nur zur Identifizierung der Qualitätsklasse und muss vor dem Einsetzen in die Spannmutter entfernt werden!
Attention: Blue plastic ring is for identification purposes only and must be removed before use!

POWER COLLET SPANNZANGE FÜR HAIMER POWER/HIGH PRECISION COLLET CHUCK

POWER COLLET FOR HAIMER POWER/HIGH PRECISION COLLET CHUCK

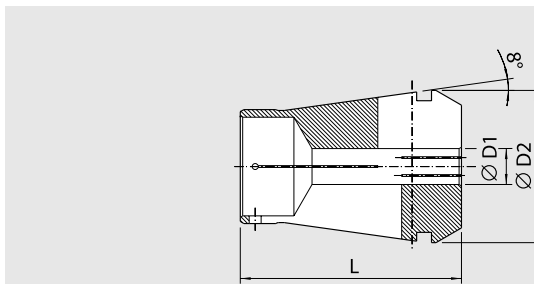

- Hohe Rundlaufgenauigkeit: 0,003 mm bei 3 x D
- Überlegene Haltekräfte
- Passend für HAIMER Power Collet Chucks und High Precision Collet Chucks
- Für Werkzeuge mit zylindrischem Schaft mit Schafttoleranz h10
- Optional: Cool Jet Bohrungen bei selbstdichtenden Spannanzgen

- High runout accuracy: 0,003 mm at 3 x D
- Superior clamping strength
- Fits HAIMER Power Collet Chucks and High Precision Collet Chucks
- For cylindrical shanks with tolerance h10
- Optional: Cool Jet bores at self-sealing collets

Bestell-Nr. Order No.	ER Größe ER Size	[mm]	D [mm]	L [mm]
81.163.02	ER16	2	16,45	30
81.163.03	ER16	3	16,45	30
81.163.04	ER16	4 ¹⁾	16,45	30
81.163.045	ER16	4,5 ¹⁾	16,45	30
81.163.05	ER16	5 ¹⁾	16,45	30
81.163.06	ER16	6 ¹⁾	16,45	30
81.163.08	ER16	8 ¹⁾	16,45	30
81.163.10	ER16	10 ¹⁾	16,45	30
81.163.00	ER16	Power Collet Spannzangensatz (beinhaltet 8 Stk., Ø 2–10 mm) Set of Power Collets (includes 8 pcs., Ø 2–10 mm)		

Bestell-Nr. Order No.	ER Größe ER Size	[mm]	D [mm]	L [mm]
81.323.02	ER32	2	32,48	45
81.323.03	ER32	3	32,48	45
81.323.04	ER32	4	32,48	45
81.323.05	ER32	5 ¹⁾	32,48	45
81.323.06	ER32	6 ¹⁾	32,48	45
81.323.08	ER32	8 ¹⁾	32,48	45
81.323.10	ER32	10 ¹⁾	32,48	45
81.323.12	ER32	12 ¹⁾	32,48	45
81.323.14	ER32	14 ¹⁾	32,48	45
81.323.16	ER32	16 ¹⁾	32,48	45
81.323.18	ER32	18 ¹⁾	32,48	45
81.323.20	ER32	20 ¹⁾	32,48	45
81.323.00	ER32	Power Collet Spannzangensatz (beinhaltet 12 Stk., Ø 2–20 mm) Set of Power Collets (includes 12 pcs., Ø 2–20 mm)		

Bestell-Nr. Order No.	ER Größe ER Size	[mm]	D [mm]	L [mm]
81.253.02	ER25	2	25,45	37
81.253.03	ER25	3	25,45	37
81.253.04	ER25	4	25,45	37
81.253.05	ER25	5 ¹⁾	25,45	37
81.253.06	ER25	6 ¹⁾	25,45	37
81.253.08	ER25	8 ¹⁾	25,45	37
81.253.10	ER25	10 ¹⁾	25,45	37
81.253.12	ER25	12 ¹⁾	25,45	37
81.253.14	ER25	14 ¹⁾	25,45	37
81.253.16	ER25	16 ¹⁾	25,45	37
81.253.00	ER25	Power Collet Spannzangensatz (beinhaltet 10 Stk., Ø 2–16 mm) Set of Power Collets (includes 10 pcs., Ø 2–16 mm)		

1) Selbstdichtend für Innenkühlung/Sealed for internal coolant

POWER COLLET SPANNZANGEN MIT SAFE-LOCK® POWER COLLET WITH SAFE-LOCK®

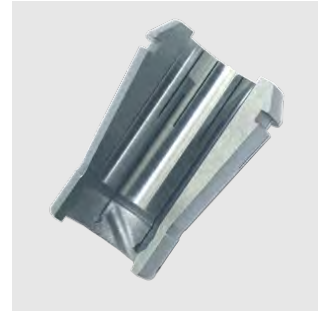
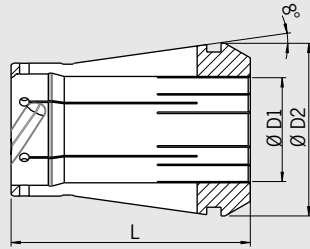

- Hochgenaue Spannung durch Power Collet Spannanzgen
- Hohes Drehmoment durch formschlüssige Mitnahme
- Kein Verlust an Rundlaufgenauigkeit
- Kein Ausziehen und Durchdrehen des Werkzeuges
- Nut am Fräserschaft wird so ausgerichtet, dass der Fräser in das Futter hinein gezogen wird
- Selbstdichtend für Innenkühlung
- Optional: Cool Jet Bohrungen

- High-precision Power Collets with stabilisation and concentration trough pilot of collet
- High torque due to form closed clamping
- No pull out and no spinning of the tool
- Groove on tool shank is directed so that the tool will be pulled into the chuck (depending on direction of rotation)
- Sealed for internal coolant
- Optional: Cool Jet bores

Bestell-Nr. Order No.	ER Größe ER Size	[mm]	D [mm]	L [mm]
81.163.06.7	ER16	6	16,45	30
81.163.08.7	ER16	8	16,45	30
81.163.10.7	ER16	10	16,45	30

Bestell-Nr. Order No.	ER Größe ER Size	[mm]	D [mm]	L [mm]				
81.253.06.7	ER25	6	25,45	37				
81.253.08.7	ER25	8	25,45	37				
81.253.10.7	ER25	10	25,45	37				
81.253.12.7	ER25	12	25,45	37				
81.253.14.7	ER25	14	25,45 </tr <tr> <td>81.253.16.7</td> <td>ER25</td> <td>16</td> <td>25,45</td> <td>37</td> </tr>	81.253.16.7	ER25	16	25,45	37
81.253.16.7	ER25	16	25,45	37				

Bestell-Nr. Order No.	ER Größe ER Size	[mm]	D [mm]	L [mm]
81.323.06.7	ER32	6	32,48	45
81.323.08.7	ER32	8	32,48	45
81.323.10.7	ER32	10	32,48	45
81.323.12.7	ER32	12	32,48	45
81.323.14.7	ER32	14	32,48	45
81.323.16.7	ER32	16	32,48	45
81.323.18.7	ER32	18	32,48	45
81.323.20.7	ER32	20	32,48	45

COOL JET BOHRUNGEN FÜR POWER COLLET SPANNZANGEN COOL JET BORES FOR POWER COLLETS

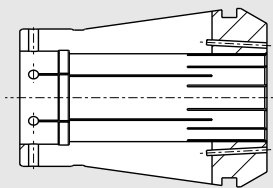

Optional: Cool Jet für Power Collets

- Optimierte schräge Kühlmittelbohrungen in der Spannanzge
- Optimale Strahlenkung bis an die Schneide
- Bis zu 100% höhere Standzeiten
- Erhöhte Prozesssicherheit
- Keine Späneknäuel am Werkzeug
- Erhältlich für selbstdichtende Power Collet Spannanzgen

Optional: Cool Jet for Power Collets

- Optimized coolant bores, aimed at center in the collet
- Coolant directly to the cutting edge
- Extended tool life up to 100%
- Higher reliability of cutting process
- No more balls of chips on tools
- Available for self-sealing Power Collets

Cool Jet Bohrungen für Power Collet Spannanzgen/Cool Jet bores for Power Collets

Bestell-Nr./Order No. 91.100.27

TORQUE MASTER DREHMOMENTSCHLÜSSEL FÜR HAIMER POWER COLLET CHUCK UND STANDARD ER FUTTER

TORQUE MASTER TORQUE WRENCH FOR HAIMER POWER COLLET CHUCK AND STANDARD ER CHUCKS

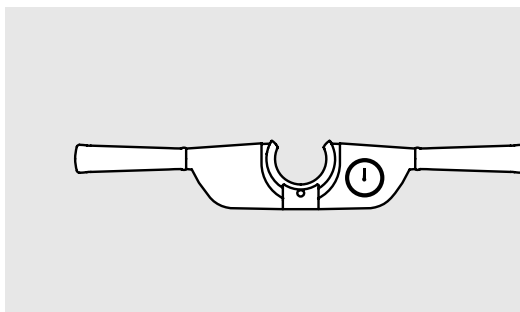

Zweiarmiger Drehmomentschlüssel für Power Collet Chucks:

- Für höchste Rundlaufgenauigkeit, kein einseitiges Spannen
- Optimale Kraftübertragung durch gleichmäßige Krafteinleitung
- Drehmomentschlüssel für höchste Spann- und Wiederholgenauigkeit mit Messuhr
- Maximales Drehmoment für höchste Haltekräfte
- Keine Überlastung kleiner Spanndurchmesser
- Auswechselbare Einsätze, auch für Standard ER-Muttern geeignet

Two-armed torque wrench for Power Collet Chucks:

- For highest runout accuracy, no one-sided clamping
- Optimal power transmission by constant force application
- Torque wrench for highest clamping accuracy and repeatability with dial gauge
- Maximum torque for highest clamping force
- No overloading of smaller clamping diameters
- Changeable inserts, useable also for standard ER-Collets

Torque Master Drehmomentschlüssel/Torque wrench	Bestell-Nr./Order No.
Torque Master Drehmomentschlüssel im Koffer/with suitcase	84.600.00
Torque Master Drehmomentschlüssel ohne Koffer/without suitcase	84.600.00.S
Torque Master Drehmomentschlüssel Set mit Koffer und 3 Einsätzen für Standard ER Futter in ER16, ER25, ER32	84.600.00.AK
Torque Master torque wrench set with suitcase and 3 inserts for Standard ER Chucks in ER16, ER25, ER32	

EINSÄTZE FÜR TORQUE MASTER DREHMOMENTSCHLÜSSEL

INSERTS FOR TORQUE MASTER TORQUE WRENCH

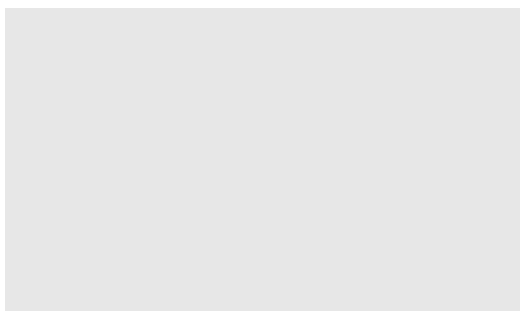

Einsätze für Torque Master Drehmomentschlüssel/Inserts for Torque Master wrench		
für Power Collet Chucks/ for Power Collet Chucks	Größe/Size	
Bestell-Nr./Order No.		
84.610.16	ER16	
84.610.25	ER25	
84.610.32	ER32	
für Standard ER Futter/ for Standard ER Chucks	Größe/Size	Schlüsselweite SW/Wrench size SW
84.620.11	ER11	SW17
84.620.16	ER16	SW25
84.620.20	ER20	SW30
84.620.25	ER25	
84.620.32	ER32	
für Standard ER Futter ER Mini/ for Standard ER Chucks ER Mini	Größe/Size	Schlüsselweite SW/Wrench size SW
84.620.16.1	ER16 Mini	

SPANNSCHLÜSSEL WRENCHES



Power Collet Spannschlüssel für ER 16, ER 25 und ER 32/Power Collet clamping wrench for ER 16, ER 25 and ER 32

ER	ER 16	ER 25	ER 32
Bestell-Nr./Order No. 84.650...	.16	.25	.32

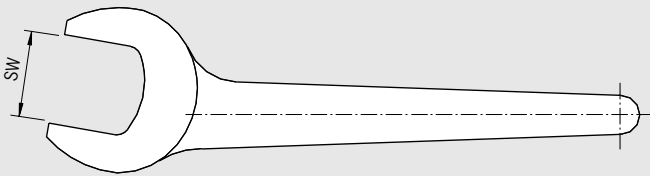

Gabelschlüssel für Spannmutter ER 11, ER 16 und ER 20/Wrench for locknuts ER 11, ER 16 and ER 20

ER	ER 11	ER 16	ER 20
Schlüsselweite SW/Wrench size	17	25	30
Bestell-Nr./Order No. 84.200...	.11	.16	.20

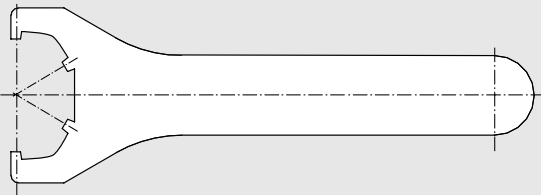

Spannschlüssel für Spannmutter ER 25-50/Wrench for locknuts ER 25-50

ER	ER 25	ER 32	ER 40	ER 50
Bestell-Nr./Order No. 84.200...	.25	.32	.40	.50

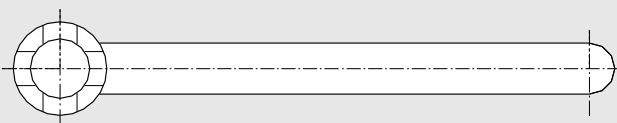

Nasenschlüssel DIN 6368 für Kombiaufsteckfräserdorne und Messerkopfaufnahmen Ø 16-60
Wrench for tightening bolts for face mill arbors and combination shell end mill adapters Ø 16-60

Ø	16	22	27	32	40	50	60
Bestell-Nr./Order No. 84.400...	.16	.22	.27	.32	.40	.50	.60

ROLLENSPANNSCHLÜSSEL FÜR HIGH PRECISION COLLET CHUCKS ROLLER BEARING WRENCH FOR HIGH PRECISION COLLET CHUCKS

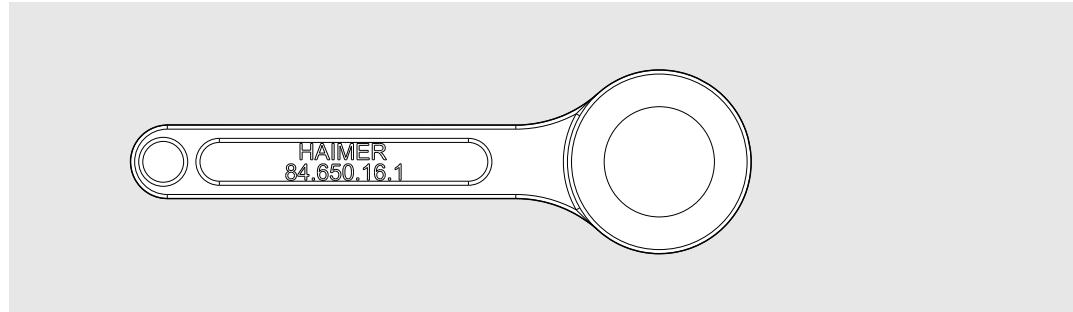

Rollenspannschlüssel zum Spannen der Hochpräzisionsspannmuttern.

Roller bearing wrench for clamping of locknuts for High Precision Collet Chucks.

Rollenspannschlüssel für ER 16, ER 25 und ER 32 / Roller bearing wrench for ER 16, ER 25 and ER 32

ER	ER 16	ER 25	ER 32
Bestell-Nr./Order No. 84.650...	.16.1	.25.1	.32.1

GLATTMUTTERN FÜR HIGH PRECISION COLLET CHUCKS SMOOTH LOCKNUTS FOR HIGH PRECISION COLLET CHUCKS

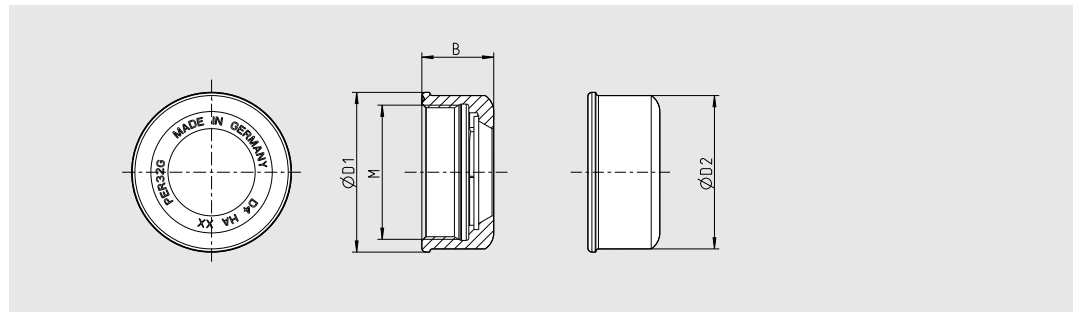

Hochpräzisions-Glattmuttern ER:

- Höchste Rundlaufgenauigkeit
- Kein Verschleiß und hohe Spannkraft durch spezielle Gleitbeschichtung
- Geringe Vibrationen durch Vorwuchtung
- Geräuschreduzierend

High Precision Smooth Locknuts ER:

- Highest run-out accuracy
- No wear and high clamping force due to special slide coating
- Less vibrations due to pre-balancing
- Noise reducing

ER	ER 16	ER 25	ER 32
Bestell-Nr./Order No. 83.914...	.16.1	.25.1	.32.1
Ø D1	28	42	50
Ø D2	27	40	48
M	M 23 x 1,5	M 34 x 1,5	M 42 x 1,5
B	17,8	20	22,5

SPANNMUTTERN FÜR SPANZANGENFUTTER LOCKNUTS FOR COLLET CHUCKS

ER 11–20
für Gabelschlüssel
for fork wrench

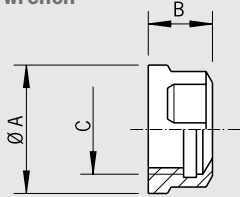

ER 25–40
für ER Spannschlüssel
for ER clamping wrench

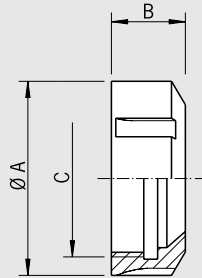

Spannmuttern ER:

- Höchste Rundlaufgenauigkeit
- Kein Verschleiß und hohe Spannkraft durch spezielle Gleitbeschichtung
- Geringe Vibrationen durch Vorwuchtung
- Ausführung HS feingewuchtet

Locknuts ER:

- Highest runout accuracy
- No wear and high clamping force due to special slide coating
- Small vibrations due to pre-balancing
- Version HS fine-balanced

ER	ER 11	ER 16	ER 20	
Bestell-Nr./Order No. 83.912...	.11	.16	.20	
HS Version				
Bestell-Nr./Order No. 83.912...		.16.HS	.20.HS	
Ø A	19	28	34	
B	11,3	17	19	
C	M 14 x 0,75	M 22 x 1,5	M 25 x 1,5	
ER		ER 25	ER 32	ER 40
Bestell-Nr./Order No. 83.912...		.25	.32	.40
HS Version				
Bestell-Nr./Order No. 83.912...		.25.HS	.32.HS	.40.HS
Ø A		42	50	63
B		20	22,5	25,5
C		M 32 x 1,5	M 40 x 1,5	M 50 x 1,5

SPANNMUTTERN FÜR POWER COLLET CHUCKS LOCKNUTS FOR POWER COLLET CHUCKS

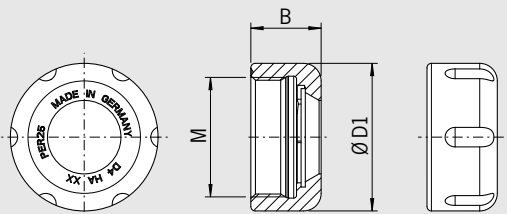

Power Collet Spannmuttern:

- Höchste Rundlaufgenauigkeit
- Kein Verschleiß und hohe Spannkraft durch spezielle Gleitbeschichtung
- Geringe Vibrationen durch Vorwuchtung

Power Collet locknuts:

- Highest run-out accuracy
- No wear and high clamping force due to special slide coating
- Less vibrations due to pre-balancing

ER	ER 16	ER 25	ER 32
Bestell-Nr./Order No. 83.914...	.16	.25	.32
Ø D1	28	42	50
M	M 23 x 1.5	M 34 x 1.5	M 42 x 1.5
B	17.8	20	22.5

HG-SPANNZANGEN UND HG-KEGELWISCHER HG COLLETS AND HG CONE WIPER

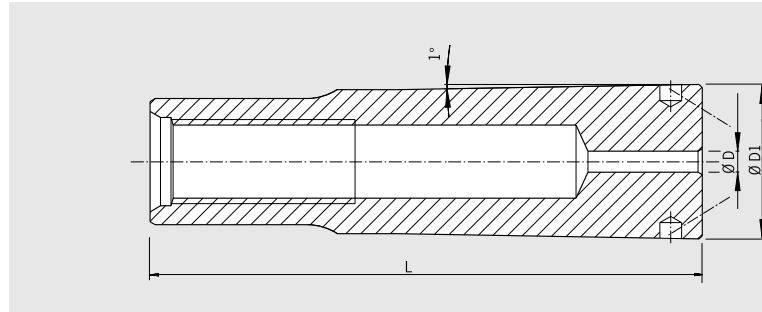

HG-Spannzangen

Zum hochgenauen Spannen von Werkzeugen mit zylindrischem Schaft in HG-Futtern.

– Für Werkzeuge mit Schafttoleranz h6

HG Collets

For clamping tools with cylindrical shank with utmost precision in HG chucks.

– For tools with Shank tolerance h6

HG 01	Ø D [mm]	2	2,5	3	4	4,5	5	5,5	5,6 ¹⁾	6	6,3	7	7,1 ¹⁾	8	9
	Ø D1[mm]	14,7	14,7	14,7	14,7	14,7	14,7	14,7	14,7	14,7	14,7	14,7	14,7	14,7	14,7
	L [mm]	52,5	52,5	52,5	52,5	52,5	52,5	52,5	52,5	52,5	52,5	52,5	52,5	52,5	52,5
Bestell-Nr./Order No. 82.510...		.02	.02.5	.03	.04	.04.5	.05	.05.5	.05.6	.06	.06.3	.07	.07.1	.08	.09
HG 02	Ø D [mm]	10		11		12		12,5		14					
	Ø D1[mm]	17,87		17,87		17,87		17,87		17,87					
	L [mm]	64,2		64,2		64,2		64,2		64,2					
Bestell-Nr./Order No. 82.520...		.10		.11		.12		.12.5		.14					
HG 03	Ø D [mm]	16		18		20									
	Ø D1[mm]	26,147		26,147		26,147									
	L [mm]	69,7		69,7		69,7									
Bestell-Nr./Order No. 82.530...		.16		.18		.20									

Zubehör/Accessories

Ausziehhaken/Pull-out hook

HG

Bestell-Nr./Order No. 82.570.00



Schmierpaste/Lubricating paste

Bestell-Nr./Order No. 82.585.00

Cool Jet Bohrungen/Cool Jet bores

Bestell-Nr./Order No. 91.100.24



Siehe Seite 468/See page 468

Kegelwischer

Zum Reinigen des Innenkonus des HG-Futters.

Cone wiper

For cleaning tool holder I.D. of HG chuck.

Kegelwischer/Cone wiper	HG 01	HG 02	HG 03
Bestell-Nr./Order No. 82.590...	.01	.02	.03

HG MINI VERLÄNGERUNGEN HG MINI EXTENSIONS

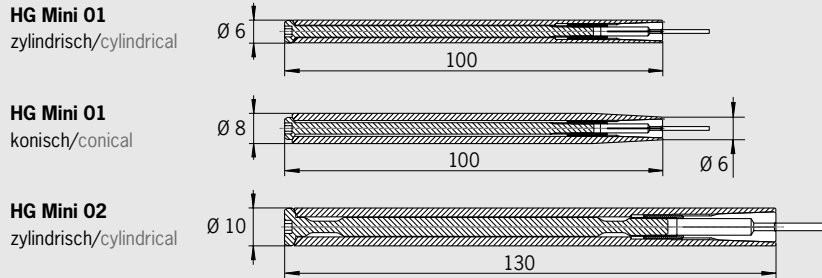

HG Mini Verlängerungen

Zum hochgenauen Spannen von Werkzeugen mit zylindrischem Schaft.

– Für Werkzeuge mit Schafttoleranz h6

HG Mini Extensions

For clamping tools with cylindrical shank with utmost precision.

– For tools with Shank tolerance h6

	HG Mini 01 zylindrisch/cylindrical	HG Mini 01 konisch/conical	HG Mini 02 zylindrisch/cylindrical
Größe/Size	A=100 mm	A=100 mm	A=130 mm
Außen-Ø/Outer diam.	6 mm zylindrisch/cylindrical	6–8 mm konisch/conical	10 mm zylindrisch/cylindrical
Spannbereich/Clamping range Ø	1–2,5 mm	1–2,5 mm	2,0–4,5 mm
Bestell-Nr./Order No.	82.611.01	82.621.01	82.610.02

Spannzangen für HG Mini 01/Collets for HG Mini 01

Spann/Clamping Ø D [mm]	1	1,5	2	2,5
Bestell-Nr./Order No. 82.650...	.010	.015	.020	.025

Spannzangen für HG Mini 02/Collets for HG Mini 02

Spann/Clamping Ø D [mm]	2	2,5	3	3,5	4	4,5
Bestell-Nr./Order No. 82.660...	.020	.025	.030	.035	.040	.045



HG Mini mit Drehmomentschlüssel und Montagehilfe
HG Mini with torque wrench and assembly device



Montagehilfe für HG Mini
Assembly device for HG Mini

Zubehör/Accessories

Drehmomentschlüssel für HG Mini (voreingestellt)/Torque wrench for HG Mini (pre-adjusted)

Größe/Size	01	02
Bestell-Nr./Order No.	82.576.00	82.577.00
Montagehilfe für HG Mini/Assembly device for HG Mini	82.578.00	
Bestell-Nr./Order No.	82.578.00	

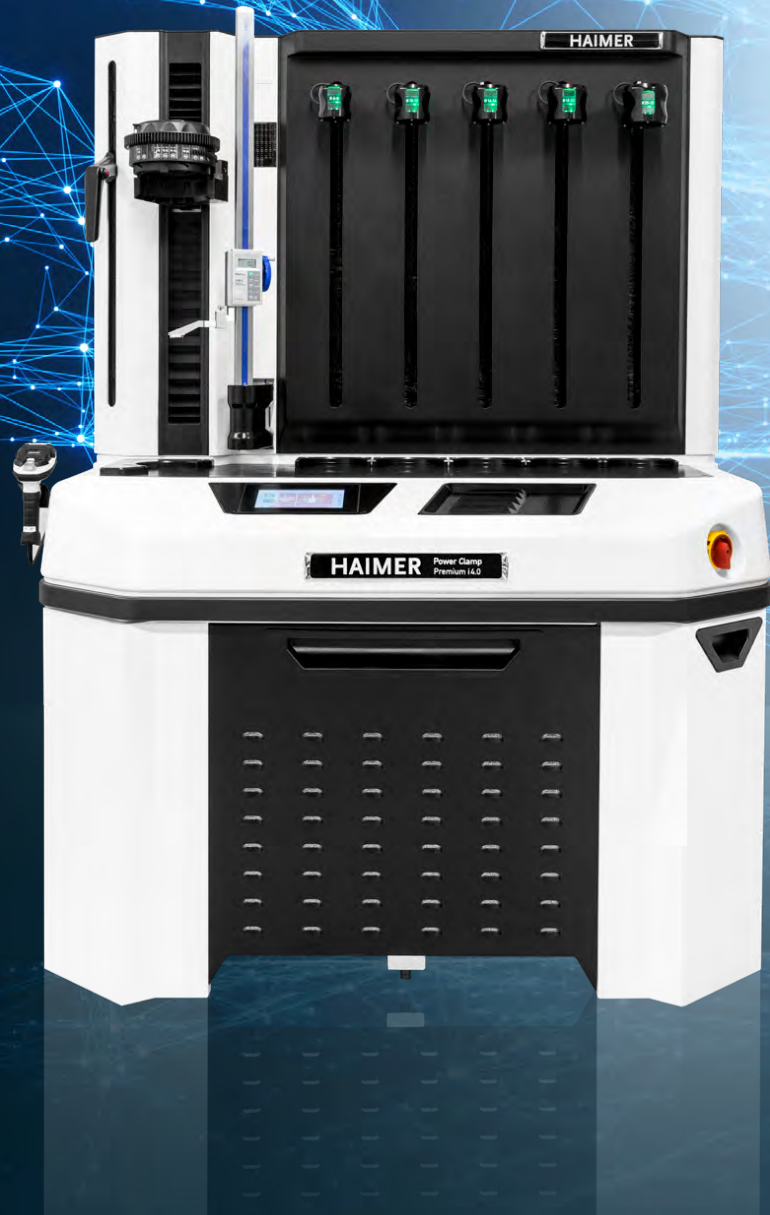

HAIMER Power Clamp

**Für schnellste Werkzeugwechsel
und höchste Prozesssicherheit**

**For fastest tool change and
highest process stability**

ANZUGSBOLZEN PULL STUDS

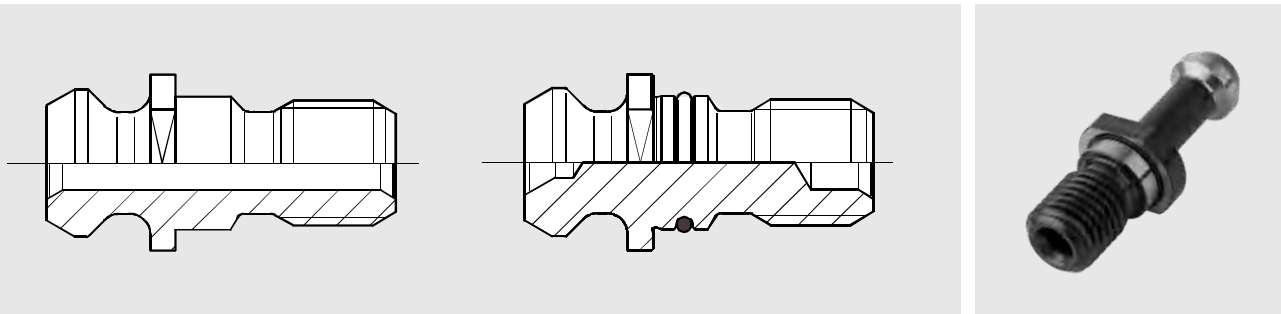

Anzugsbolzen sind ein wichtiges Bindeglied zwischen Maschine und Werkzeug. Die Anforderungen an Genauigkeit, Festigkeit und Zuverlässigkeit sind hoch. Minderwertige Anzugsbolzen beeinträchtigen nicht nur die Leistungsfähigkeit der Maschine, sondern sie stellen sogar ein Sicherheitsrisiko dar. Brechende Anzugsbolzen können nicht nur Kosten an Maschine und Werkstück verursachen, sondern auch schwere Personenschäden.

Pull studs are an important link between machine and tool. The requirements concerning accuracy, rigidity and reliability are very high. Pull studs of minor quality not only decrease the performance of the machine, they are even a safety risk. A breaking pull stud might cause severe damage on machine and workpiece and even injuries on persons.

- Gefertigt aus hochfestem Spezialstahl
- Aufwändige Wärmebehandlung in mehreren Schritten
- Hohe Schlagzähigkeit
- Alle Funktionsflächen nach dem Härten fein bearbeitet
- Höchste Sicherheit und Zuverlässigkeit

- Made of special steel with high rigidity
- Costly heat treatment in several steps
- High impact strength
- All functional surfaces fine finished after hardening
- Highest security and reliability

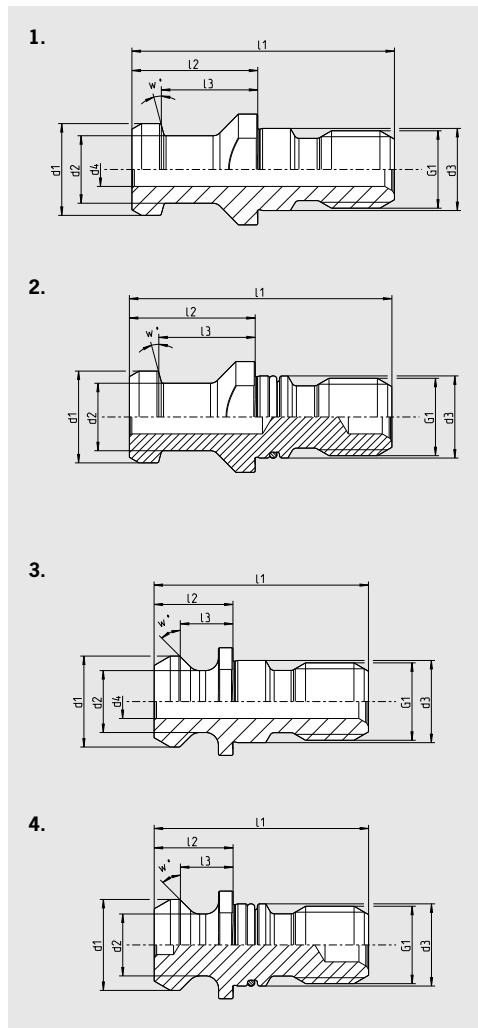

1. ISO 7388-3 Form AD mit Durchgangsbohrung/with drill through (ehemalige Norm/previous norm DIN 69872 Form A)									
	d1	d2	d3	d4	l1	l2	l3	G1	w°
SK 40									
Bestell-Nr./Order No. 88.200.40	19	14	17	7	54	26	20	M16	15°
SK 50									
Bestell-Nr./Order No. 88.200.50	28	21	25	11,5	74	34	25	M24	15°

2. ISO 7388-3 Form AF abgedichtet/sealed (ehemalige Norm/previous norm DIN 69872 Form B)									
	d1	d2	d3	d4	l1	l2	l3	G1	w°
SK 40									
Bestell-Nr./Order No. 88.202.40	19	14	17	—	54	26	20	M16	15°
SK 50									
Bestell-Nr./Order No. 88.202.50	28	21	25	—	74	34	25	M24	15°

3. ISO 7388-3 Form UD mit Durchgangsbohrung/with drill through (ehemalige Norm/previous norm ISO 7388-2 Form B)									
	d1	d2	d3	d4	l1	l2	l3	G1	w°
SK 40									
Bestell-Nr./Order No. 88.400.40	18,95	12,95	17	7	44,5	16,4	11,15	M16	45°
SK 50									
Bestell-Nr./Order No. 88.400.50	29,1	19,6	25	11,5	65,5	25,55	17,95	M24	45°

4. ISO 7388-3 Form UF abgedichtet/sealed (ehemalige Norm/previous norm ISO 7388-2 Form B)									
	d1	d2	d3	d4	l1	l2	l3	G1	w°
SK 40									
Bestell-Nr./Order No. 88.402.40	18,95	12,95	17	—	44,5	16,4	11,15	M16	45°
SK 50									
Bestell-Nr./Order No. 88.402.50	29,1	19,6	25	—	65,5	25,55	17,95	M24	45°

ANZUGSBOLZEN PULL STUDS

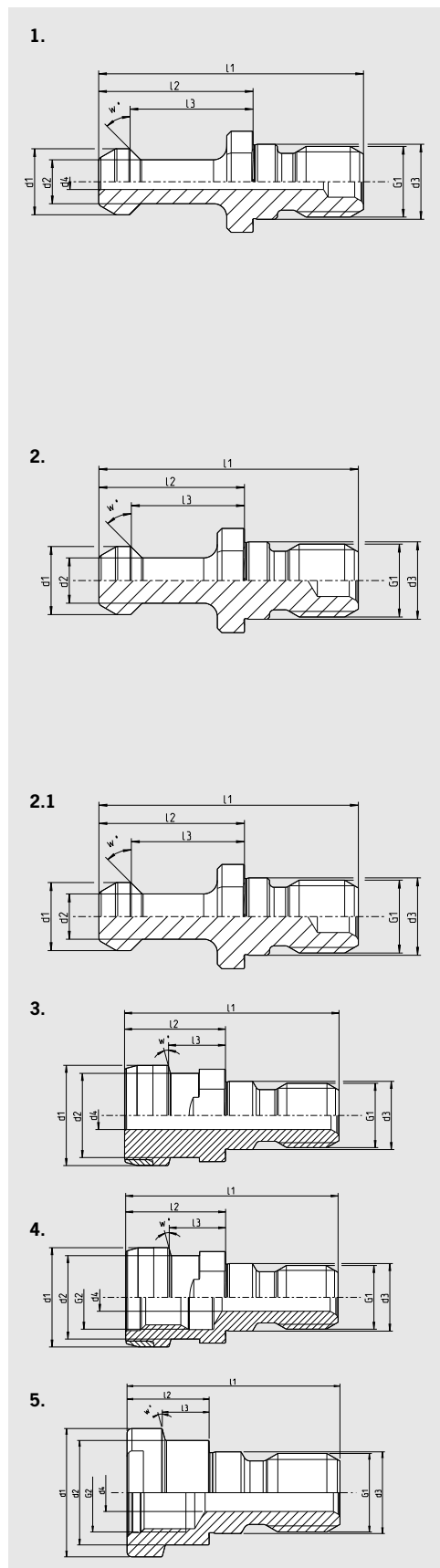

**1. ISO 7388-3 Form JD mit Durchgangsbohrung/with drill through
(ehemalige Norm/previous norm MAS 403 30°/45°)**

	d1	d2	d3	d4	l1	l2	l3	G1	w°
BT30									
Bestell-Nr./Order No. 88.605.30	11	7	12,5	2,5	43	23	18	M12	30°
BT30									
Bestell-Nr./Order No. 88.600.30	11	7	12,5	2,5	43	23	18	M12	45°
BT40									
Bestell-Nr./Order No. 88.605.40	15	10	17	3,5	60	35	28	M16	30°
BT40									
Bestell-Nr./Order No. 88.603.40	15	10	17	3,5	60	35	28	M16	45°
BT50									
Bestell-Nr./Order No. 88.605.50	23	17	25	6	85	45	35	M24	30°
BT50									
Bestell-Nr./Order No. 88.603.50	23	17	25	6	85	45	35	M24	45°

**2. ISO 7388-3 Form JF ohne Durchgangsbohrung/without drill through
(ehemalige Norm/previous norm MAS 403 30°/45°)**

	d1	d2	d3	d4	l1	l2	l3	G1	w°
BT30									
Bestell-Nr./Order No. 88.604.30	11	7	12,5	—	43	23	18	M12	30°
BT30									
Bestell-Nr./Order No. 88.601.30	11	7	12,5	—	43	23	18	M12	45°
BT40									
Bestell-Nr./Order No. 88.604.40	15	10	17	—	60	35	28	M16	30°
BT40									
Bestell-Nr./Order No. 88.601.40	15	10	17	—	60	35	28	M16	45°
BT50									
Bestell-Nr./Order No. 88.604.50	23	17	25	—	85	45	35	M24	30°
BT50									
Bestell-Nr./Order No. 88.601.50	23	17	25	—	85	45	35	M24	45°

2.1 Sonder/Special:

Ähnlich ISO 7388-3 Form JF ohne Durchgangsbohrung/without drill through

	d1	d2	d3	d4	l1	l2	l3	G1	w°
BT40 gekürzt/shortened									
Bestell-Nr./Order No. 88.601.40.1	15	10	17	—	57,1	32,15	25,15	M16	45°

**3. Ott-Ringnut mit Durchgangsbohrung/Ott-groove with drill through
Mit Messingschutzring/SK40 with protective ring of brass**

	d1	d2	d3	d4	l1	l2	l3	G1	w°
SK40									
Bestell-Nr./Order No. 88.300.40	25	21,1	17	7	53	25	13,6	M16	15°
SK50									
Bestell-Nr./Order No. 88.300.50	39,3	32	25	11,5	65	25	13,35	M24	15°

**4. Ott-Ringnut mit Innengewinde/Ott-groove with inner thread
SK40 mit Messingschutzring/SK40 with protective ring of brass**

	d1	d2	d3	d4	l1	l2	l3	G1	G2	w°
SK40										
Bestell-Nr./Order No. 88.303.40	25	21,1	17	7	53	25	13,6	M16	M16	15°

5. Ott-Ringnut mit Innengewinde/Ott-groove with inner thread

	d1	d2	d3	d4	l1	l2	l3	G1	G2	w°
SK50										
Bestell-Nr./Order No. 88.303.50	39,3	32	25	11,5	65	25	13,35	M24	M24	15°

ANZUGSBOLZEN PULL STUDS

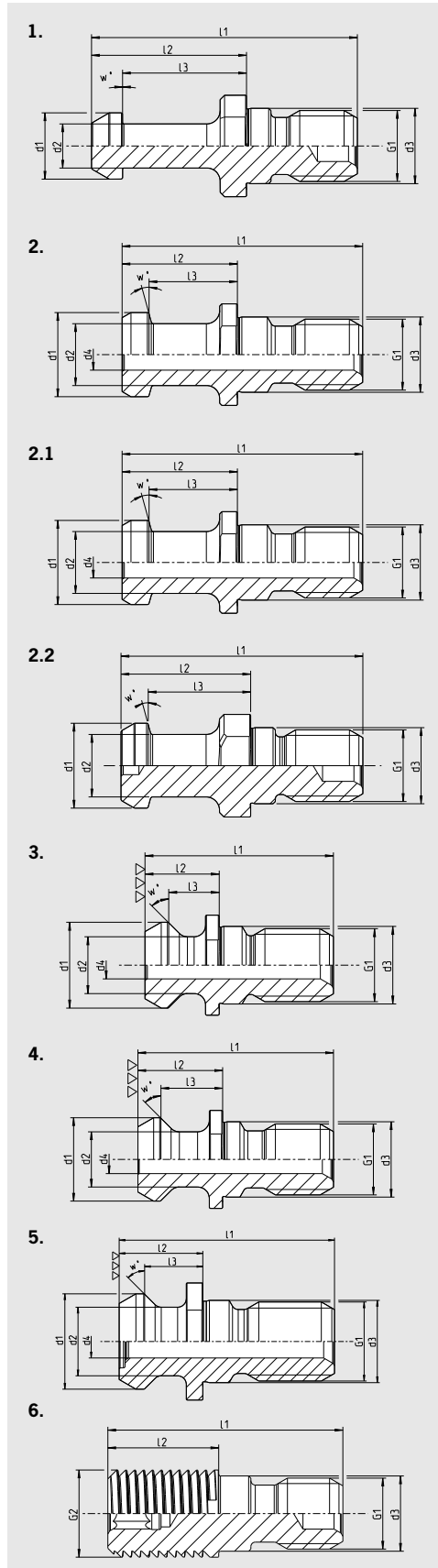

1. MORI – SEIKI MAS 90° ohne Durchgangsbohrung/without drill through

	d1	d2	d3	d4	l1	l2	l3	G1	w°
BT40									
Bestell-Nr./Order No. 88.101.40	15	10	17	—	60	35	28	M16	0°
BT50									
Bestell-Nr./Order No. 88.101.50	23	17	25	—	85	45	35	M24	0°

2. ISO 7388-2 Typ/Type A mit Durchgangsbohrung/with drill through

	d1	d2	d3	d4	l1	l2	l3	G1	w°
SK40									
Bestell-Nr./Order No. 88.800.40	19	14	17	7	54	26	20	M16	15°
SK50									
Bestell-Nr./Order No. 88.800.50	28	21	25	11,5	74	34	25	M24	15°

2.1 JIS B 6339 mit Durchgangsbohrung/with drill through

	d1	d2	d3	d4	l1	l2	l3	G1	w°
BT40									
Bestell-Nr./Order No. 88.700.40	19	14	17	7	54	29	23	M16	15°
BT50									
Bestell-Nr./Order No. 88.700.50	28	21	25	10	74	34	25	M24	15°

2.2 JIS B 6339 ohne Durchgangsbohrung/without drill through

	d1	d2	d3	d4	l1	l2	l3	G1	w°
BT40									
Bestell-Nr./Order No. 88.701.40	19	14	17	—	54	29	23	M16	15°

3. ANSI – CAT (MAZAK) mit Durchgangsbohrung/with drill through
Mit Dichtfläche stirnseitig und Passung/sealing on face side and pilot

	d1	d2	d3	d4	l1	l2	l3	G1	w°
CAT40									
Bestell-Nr./Order No. 88.500.40	18,80	12,45	17	6	41,26	16,26	11,18	M16	45°
CAT40 mit Passungssitz/with pilot									
Bestell-Nr./Order No. 88.500.40.1	18,80	12,45	17	7	41,26	16,26	11,18	M16	45°

4. ANSI – CAT 40 (MAZAK) mit Durchgangsbohrung/with drill through
Mit Dichtfläche stirnseitig und Passung/sealing on face side and pilot

	d1	d2	d3	d4	l1	l2	l3	G1	w°
CAT40 verlängert/extended									
Bestell-Nr./Order No. 88.900.40.1	18,8	12,45	17	6,4	44,11	19,11	14,03	M16	45°

5. ANSI – CAT 50 (MAZAK) mit Durchgangsbohrung/with drill through
Mit Dichtfläche stirnseitig und Passung/sealing on face side and pilot

	d1	d2	d3	d4	l1	l2	l3	G1	w°
CAT50									
Bestell-Nr./Order No. 88.500.50	28,96	20,83	25	10	65,4	25,4	17,78	M24	45°

6. Anzugsbolzen mit Sägewinde S 20×2/with saw thread S 20×2

	d1	d2	d3	d4	l1	l2	l3	G1	G2	w°
SK40										
Bestell-Nr./Order No. 88.600.40	—	—	17	—	53	25	—	M16	S20×2	0°

SÄGEBLATTAFNAHME SAWBLADE HOLDER

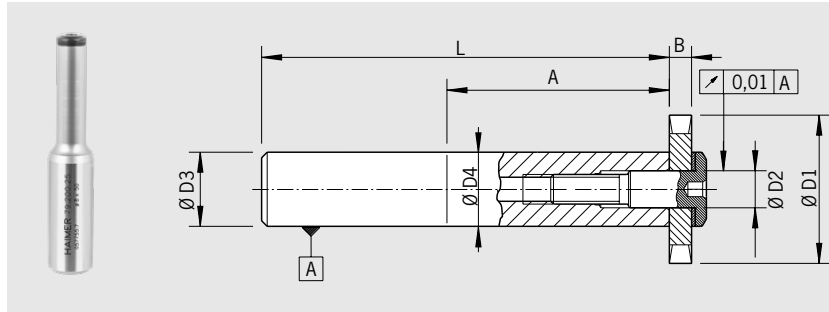

Verwendung:

Zur Aufnahme von Sägeblättern in Standard Aufnahmen.

Schaftausführung nach

DIN 1835-A

hochvergütet, Außen- und Innen-Ø geschliffen

- Lieferumfang: komplett mit Spannschraube und Zwischenring
- Kühlung mit Cool Jet gegen Aufpreis

Use:

For holding sawblades on standard tool holders.

Design of shank according to

DIN 1835-A

well quenched and tempered, internally and externally ground

- Included in delivery: completely with tightening bolt and intermediate disk
- Cooling with Cool Jet against extra charge

Sägeblatt/Sawblade Ø D1 [mm]	20	25	32	40	50	63
Ø D2 [mm]	5	8	8	10	13	16
Ø D3 [mm]	20	20	20	20	25	25
Ø D4 [mm]	10	13	16	20	25	25
L [mm]	90	100	105	110	136	136
B 0,2 mm – 6 mm						
Maß/Length A [mm]	40	50	55	60	80	80
Bestell-Nr./Order No. 79.200...	.20.3	.25.3	.32.3	.40.3	.50.3	.63.3

Sägeblattaufnahmensatz

bestehend aus allen sechs Größen inkl. Werkzeugträger/Tool bar incl. 6 pcs. sawblade adapter

Bestell-Nr./Order No. 79.200.00.3

Zubehör/Accessories

Spannschraube/Tightening bolt

Größe/Size D1

Bestell-Nr./Order No. 79.250...

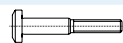

20	25	32	40	50	63
.20	.25	.32	.40	.50	.63

Scheibe/Disk

Größe/Size D1

Bestell-Nr./Order No. 79.260...



20	25	32	40	50	63
.20	.25	.32	.40	.50	.63

Cool Jet Bohrungen/Cool Jet bores

Bestell-Nr./Order No. 91.100.24



Siehe Seite 468/See page 468

SÄGEBLATTAFNAHME – MIT WELDON SCHAFT SAWBLADE HOLDER – WITH WELDON SHANK

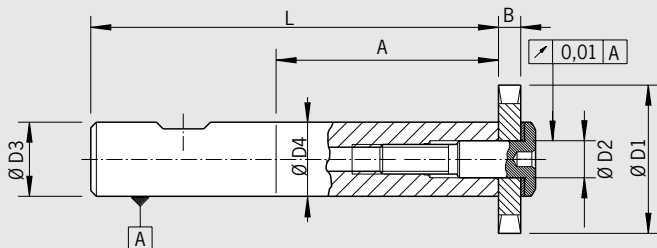

Verwendung:

Zur Aufnahme von Sägeblättern über Weldon-Aufnahmen.

Schaftausführung nach

DIN 1835-B

hochvergütet, Außen- und Innen-Ø geschliffen

- Lieferumfang: komplett mit Spannschraube und Zwischenring
- Kühlung mit Cool Jet gegen Aufpreis

Use:

For holding sawblades on Weldon tool holders.

Design of shank according to

DIN 1835-B

well quenched and tempered, internally and externally ground

- Included in delivery: completely with tightening bolt and intermediate disk
- Cooling with Cool Jet against extra charge

Sägeblatt/Sawblade Ø D1 [mm]	20	25	32	40	50	63
Ø D2 [mm]	5	8	8	10	13	16
Ø D3 [mm]	20	20	20	20	25	25
Ø D4 [mm]	10	13	16	20	25	25
L [mm]	90	100	105	110	136	136
B 0,2 mm – 6 mm						
Maß/Length A [mm]	40	50	55	60	80	80
Bestell-Nr./Order No. 79.200...	.20	.25	.32	.40	.50	.63

Sägeblattaufnahmensatz

bestehend aus allen sechs Größen inkl. Werkzeugträger/Tool bar incl. 6 pcs. sawblade adapter

Bestell-Nr./Order No. 79.200.00

Zubehör/Accessories

Spannschraube/Tightening bolt

Größe/Size D1

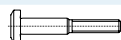

20	25	32	40	50	63
.20	.25	.32	.40	.50	.63

Scheibe/Disk

Größe/Size D1



20	25	32	40	50	63
.20	.25	.32	.40	.50	.63

Cool Jet Bohrungen/Cool Jet bores

Bestell-Nr./Order No. 91.100.24



Siehe Seite 468/See page 468

SCHRUMPFUTTERBÜRSTE SHRINK FIT BRUSH

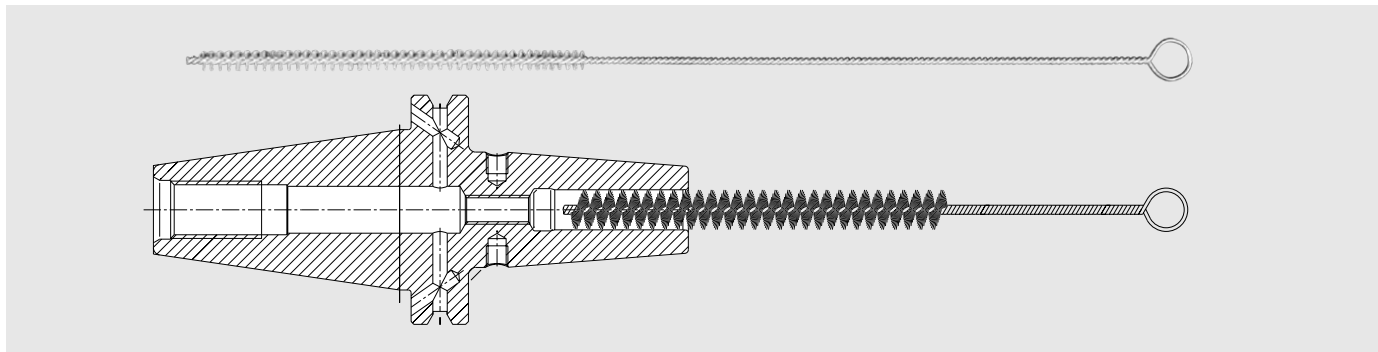

Um optimale Haltekräfte im Schrumpfsitz zu erzielen, muss die Schrumpfböhrung sauber und fettfrei sein. Die Reinigung sollte mit einem Lösungsmittel erfolgen, z. B. Bremsenreiniger. Mit der Schrumpffutterbürste kann die Schrumpfböhrung bis auf den Grund gereinigt werden.

In order to achieve the best possible shrink fit connection, a grease free socket and shank is necessary. The cleaning can be done by a cold solvent (e.g. brake cleaner). An appropriate cleaning brush is necessary to clean the socket of the Shrink Fit Chuck.

Schrumpffutterbürste/Shrink Fit Brush	Ø [mm]
Bestell-Nr./Order No. 86.200.01	3
86.200.02	3,5
86.200.02	4
86.200.02	4,5
86.200.02	5
86.200.03	6
86.200.03	8

Schrumpffutterbürste/Shrink Fit Brush	Ø [mm]
Bestell-Nr./Order No. 86.200.04	10
86.200.04	12
86.200.06	14
86.200.06	16
86.200.07	18
86.200.07	20
86.200.08	25

KÜHLMITTELROHR COOLANT TUBE

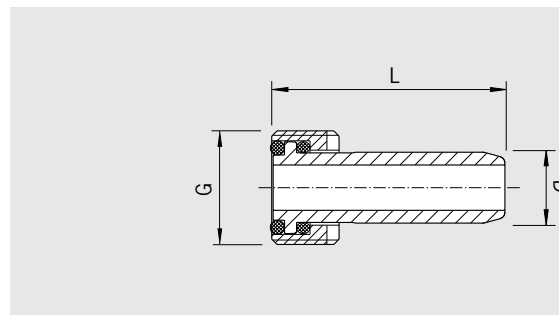

- Verhindert Verschmutzung der Spindel
- Notwendig für alle HSK-Maschinen mit Innenkühlung
- Zwei O-Ringe für leichte Beweglichkeit des Rohres
- Spezialbeschichtung mit extrem glatter Oberfläche
- Schont das Dichtsystem der Spindel
- Passend für alle Fabrikate

- Prevents spindle from being spoiled
- Must be used with all coolant through HSK spindles
- Dual o-ring design makes tube slightly movable
- Special coating with extremely smooth surface
- No damaging of the sealing system
- Fits all brands of HSK holders

Kühlmittelrohr/Coolant tube with 2 o-rings	HSK-A32	HSK-A40	HSK-A50	HSK-A63	HSK-A80	HSK-A100	HSK-A125
	HSK-E32	HSK-E40	HSK-E50				
Bestell-Nr./Order No. 85.700...	.32	.40	.50	.63	.80	.10	.125
Gewinde/Thread G [mm]	M10 x 1	M12 x 1	M16 x 1	M18 x 1	M20 x 1,5	M24 x 1,5	M30 x 1,5
Durchmesser/Diameter D [mm]	6	8	10	12	14	16	18
Maß/Length L [mm]	26	29,5	33	36,5	40	44	48

Zubehör/Accessories

Schlüssel für/Wrench for	HSK-32	HSK-40	HSK-50	HSK-63	HSK-80	HSK-100	HSK-125
Bestell-Nr./Order No. 84.500...	.32	.40	.50	.63	.80	.10	.125

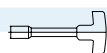

REDUZIERHÜLSEN FÜR HYDRODEHNFUTTER REDUCTION SLEEVES FOR HYDRAULIC CHUCKS

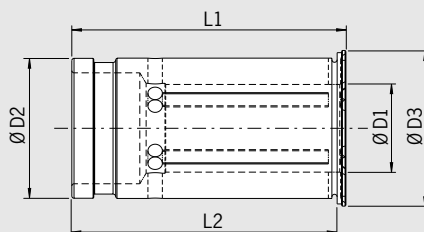

Verwendung:

Reduzierhülsen ermöglichen das Spannen mehrerer unterschiedlicher Schaftdurchmesser mit nur einer Werkzeugaufnahme. Sie können in marktgängigen Hydrodehnspannfuttern eingesetzt werden.

Ausführung:

- Abgedichtet (Kühlmitteldicht bis max. 80 bar)
- Geeignet für alle gängigen Werkzeugschäfte mit Schafttoleranz h6

Use:

Reduction sleeves allow clamping of several different shank diameters with just one tool holder. They can be used in all marketable hydraulic chucks.

Version:

- Sealed (Coolant-proof up to 80 bar)
- Suitable for all common cutting tool shanks with h6 tolerance

Bestell-Nr. Order No.	Ø D1 [mm] Ø D1 [mm]	Ø D2 [mm] Ø D2 [mm]	Ø D3 [mm] Ø D3 [mm]	L1 [mm] L1 [mm]	L2 [mm] L2 [mm]
76.120.03	3	12	16,5	47	45
76.120.04	4	12	16,5	47	45
76.120.05	5	12	16,5	47	45
76.120.06	6	12	16,5	47	45
76.120.08	8	12	16,5	47	45
76.200.03	3	20	24	52,5	50,5
76.200.04	4	20	24	52,5	50,5
76.200.05	5	20	24	52,5	50,5
76.200.06	6	20	24	52,5	50,5
76.200.08	8	20	24	52,5	50,5
76.200.10	10	20	24	52,5	50,5
76.200.12	12	20	24	52,5	50,5
76.200.14	14	20	24	52,5	50,5
76.200.16	16	20	24	52,5	50,5
76.320.06	6	32	35,5	62,5	60,5
76.320.08	8	32	35,5	62,5	60,5
76.320.10	10	32	35,5	62,5	60,5
76.320.12	12	32	35,5	62,5	60,5
76.320.14	14	32	35,5	62,5	60,5
76.320.16	16	32	35,5	62,5	60,5
76.320.18	18	32	35,5	62,5	60,5
76.320.20	20	32	35,5	62,5	60,5
76.320.25	25	32	35,5	62,5	60,5

REDUZIERHÜLSEN MIT KÜHLMITTELSCHLITZEN FÜR HYDRODEHNSPANNFUTTER REDUCTION SLEEVES WITH COOLANT SLITS FOR HYDRAULIC CHUCKS

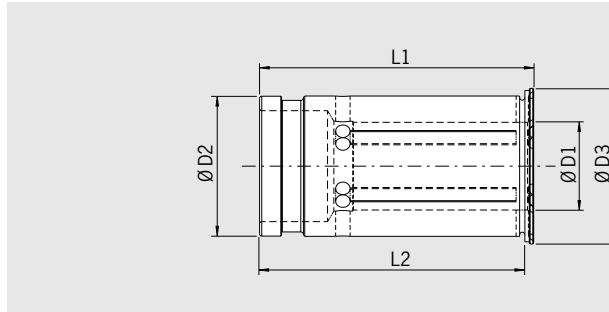

Verwendung:

Reduzierhülsen ermöglichen das Spannen mehrerer unterschiedlicher Schaftdurchmesser mit nur einer Werkzeugaufnahme. Sie können in marktgängigen Hydrodehnspannfuttern eingesetzt werden.

Die spezielle Geometrie der Kühlmittelschlitze sorgt für eine gezielte Kühlung der Werkzeugschneide.

Use:

Reduction sleeves allow clamping of several different shank diameters with just one tool holder. They can be used in all marketable hydraulic chucks.

The special geometry of coolant slits ensures targeted coolant supply of the cutting edge.

Ausführung:

– Geeignet für alle gängigen Werkzeugschäfte mit Schafttoleranz h6

Version:

– Suitable for all common cutting tool shanks with h6 tolerance

Reduzierhülsen mit Kühlmittelschlitzen für Hydrodehnspannfutter/Reduction sleeves with coolant slits for Hydraulic Chucks

Bestell-Nr. Order No.	Ø D1 [mm] Ø D1 [mm]	Ø D2 [mm] Ø D2 [mm]	Ø D3 [mm] Ø D3 [mm]	L1 [mm] L1 [mm]	L2 [mm] L2 [mm]
76.200.06.2	6	20	24	52,5	50,5
76.200.08.2	8	20	24	52,5	50,5
76.200.10.2	10	20	24	52,5	50,5
76.200.12.2	12	20	24	52,5	50,5
76.200.16.2	16	20	24	52,5	50,5
76.320.06.2	6	32	35,5	62,5	60,5
76.320.08.2	8	32	35,5	62,5	60,5
76.320.10.2	10	32	35,5	62,5	60,5
76.320.12.2	12	32	35,5	62,5	60,5
76.320.16.2	16	32	35,5	62,5	60,5

REDUZIERHÜLSEN MIT SAFE-LOCK FÜR POWER HYDRAULIC CHUCKS REDUCTION SLEEVES WITH SAFE-LOCK FOR POWER HYDRAULIC CHUCKS

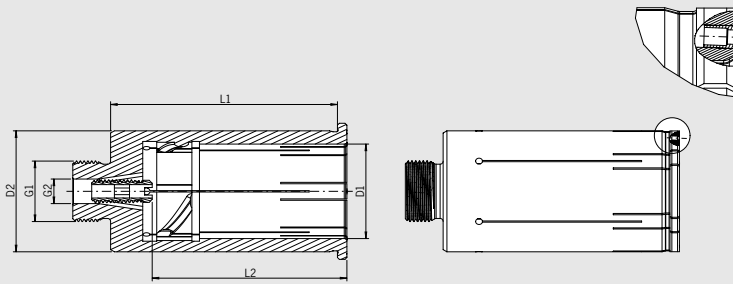

Verwendung:

Reduzierhülsen ermöglichen das Spannen mehrerer unterschiedlicher Schaftdurchmesser mit nur einer Werkzeugaufnahme. Die Reduzierhülsen mit Safe-Lock können in HAIMER Power Hydraulic Chucks eingesetzt werden, um Werkzeuge mit Safe-Lock Schaft zu spannen. Die Werkzeuge werden durch den zusätzlichen Formschluss gegen Auszug gesichert. Die Reduzierhülse wird ins Hydrodehnspannfutter eingedreht und festgeschraubt, um ebenfalls gegen Auszug gesichert zu sein.

- Kein Ausziehen und Durchdrehen des Werkzeuges
- Mit Cool Jet Bohrung für gezielte Kühlung der Werkzeugschneide
- Lieferumfang: Mit Längeneinstellschraube (Art.Nr. 85.810.15.3)

Use:

Reduction sleeves allow clamping of several different shank diameters with just one tool holder. The reduction sleeves with Safe-Lock can be used in HAIMER Power Hydraulic Chucks to clamp tools with Safe-Lock shanks. The tools are protected against pull out by the additional form lock. The reduction sleeve is screwed into the hydraulic chuck and tightened to also be secured against pull out.

- No pull out and no spinning of the tool
- With Cool Jet bores for targeted cooling of the cutting edge
- Included in delivery: with back-up screw (Order No. 85.810.15.3)

Bestell-Nr. Order No.	Ø D1 [mm] Ø D1 [mm]	Ø D2 [mm] Ø D2 [mm]	L1 [mm] L1 [mm]	L2 [mm] L2 [mm]	G1	G2
76.323.12.27	12	32	60	45	M16x1	M6
76.323.16.27	16	32	60	48	M16x1	M6
76.323.20.27	20	32	60	50	M16x1	M6
76.323.25.27	25	32	60	51	M16x1	M6

REDUZIERHÜLSEN FÜR MECHANISCHE FUTTER REDUCTION SLEEVES FOR MECHANICAL CHUCKS

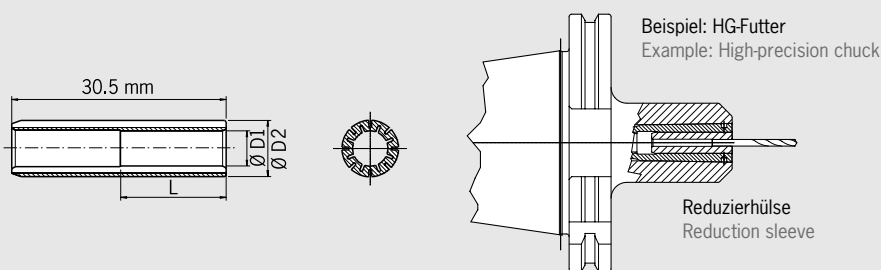

Verwendung:

Zum Spannen von kleinen Schäften in Aufnahmen mit Spanndurchmesser 8 mm.

- Schafttoleranz h6
- Abgedichtet (für Innenkühlung geeignet)

Use:

For clamping small shanks in chucks with Ø 5/16" or 8 mm ID's.

- Shank tolerance h6
- Sealed (ready for internal coolant)

Bestell-Nr. Order No.	Ø D1 [mm] Ø D1 [mm]	Ø D2 [mm] Ø D2 [mm]	L [mm] L [mm]
79.110.2.5	2,5	8	7,5
79.110.03	3	8	9
79.110.3.5	3,5	8	10,5
79.110.04	4	8	12
79.110.4.5	4,5	8	13,5
79.110.05	5	8	15
79.110.5.5	5,5	8	16,5

AUSWUCHTRINGE BALANCING INDEX RINGS

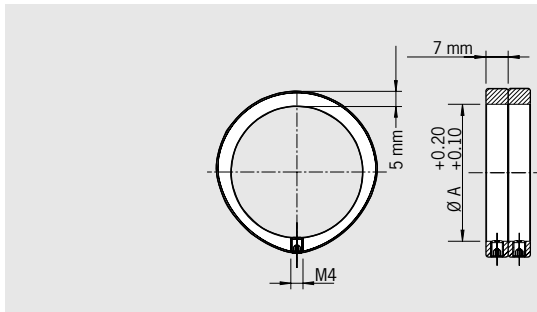

Zum Feinwuchten von allen Werkzeugaufnahmen mit zylindrischem Außendurchmesser (Ø A).

For fine-balancing of all tool holders with cylindrical outer diameter (diam. A).

Die Auswuchtringe tragen selbst eine genau definierte Unwucht. Sie werden so gedreht, dass die Unwucht der Werkzeugaufnahme genau ausgeglichen wird. Es werden immer 2 Ringe pro Auswuchtebene benötigt.

The balancing index rings have a defined unbalance in themselves. They are turned in such a position that the unbalance of the tool holder will be compensated. There are always 2 rings needed per balancing plane.

- Schnell und präzise auswuchten
- Keine Beschädigung des Futter
- Beliebig oft wiederholbar
- Einfache Fixierung mit Klemmschraube
- Passend für alle Fabrikate
- Die Auswuchtmaschine bestimmt die Position der Ringe (z. B. HAIMER Tool Dynamic)

- Balancing quickly and precisely
- No damage of tool holder
- Can be repeated as often as necessary
- Simply fixed by clamping screw
- Suitable for tool holders of all brands
- The balancing machine determines the position of the rings (e.g. HAIMER Tool Dynamic)

- Lieferumfang: 2 Auswuchtringe mit Klemmschrauben ohne Innensechskantschlüssel

- Included in delivery: 2 balancing rings with clamping screws without hex wrench

Bestell-Nr./Order No.	Ø A [mm]	Unwucht ¹⁾ unbalance	Drehzahl rpm [1/min]
79.350.15	15	14 g·mm	max. 55.000
79.350.16	16	14 g·mm	max. 55.000
79.350.17	17	16 g·mm	max. 55.000
79.350.18	18	17 g·mm	max. 55.000
79.350.19	19	19 g·mm	max. 55.000
79.350.20	20	21 g·mm	max. 55.000
79.350.22	22	23 g·mm	max. 55.000
79.350.23	23	25 g·mm	max. 55.000
79.350.24	24	27 g·mm	max. 55.000
79.350.25	25	28 g·mm	max. 55.000
79.350.26	26	32 g·mm	max. 50.000
79.350.27	27	32,5 g·mm	max. 50.000
79.350.28	28	34 g·mm	max. 50.000
79.350.30	30	37 g·mm	max. 45.000
79.350.32	32	43 g·mm	max. 45.000
79.350.34	34	46 g·mm	max. 40.000
79.350.35	35	48 g·mm	max. 40.000
79.350.36	36	51 g·mm	max. 40.000
79.350.38	38	56 g·mm	max. 35.000
79.350.40	40	60 g·mm	max. 35.000
79.350.42	42	65 g·mm	max. 35.000
79.350.43	43	69 g·mm	max. 35.000
79.350.44	44	72 g·mm	max. 35.000
79.350.46	46	80 g·mm	max. 35.000
79.350.48	48	85 g·mm	max. 30.000
79.350.50	50	90 g·mm	max. 30.000
79.350.52	52	100 g·mm	max. 30.000
79.350.53	53	100 g·mm	max. 30.000
79.350.54	54	103 g·mm	max. 30.000

Bestell-Nr./Order No.	Ø A [mm]	Unwucht ¹⁾ unbalance	Drehzahl rpm [1/min]
79.350.55	55	105 g·mm	max. 30.000
79.350.56	56	110 g·mm	max. 30.000
79.350.58	58	120 g·mm	max. 30.000
79.350.60	60	128 g·mm	max. 25.000
79.350.62	62	132 g·mm	max. 25.000
79.350.63	63	135 g·mm	max. 25.000
79.350.64	64	147 g·mm	max. 25.000
79.350.65	65	147 g·mm	max. 25.000
79.350.66	66	145 g·mm	max. 25.000
79.350.68	68	161 g·mm	max. 25.000
79.350.70	70	165 g·mm	max. 25.000
79.350.72	72	170 g·mm	max. 25.000
79.350.74	74	184 g·mm	max. 25.000
79.350.76	76	186 g·mm	max. 20.000
79.350.78	78	206 g·mm	max. 20.000
79.350.80	80	215 g·mm	max. 20.000
79.350.82	82	213 g·mm	max. 20.000
79.350.84	84	229 g·mm	max. 20.000
79.350.86	86	249 g·mm	max. 20.000
79.350.87	87	256 g·mm	max. 20.000
79.350.88	88	251 g·mm	max. 20.000
79.350.89	89	260 g·mm	max. 20.000
79.350.90	90	265 g·mm	max. 20.000
79.350.92	92	275 g·mm	max. 20.000
79.350.94	94	286 g·mm	max. 20.000
79.350.96	96	300 g·mm	max. 20.000
79.350.98	98	305 g·mm	max. 20.000
79.350.100	100	320 g·mm	max. 15.000
79.350.125	125	500 g·mm	max. 15.000

1) Unwucht g·mm sind Richtwerte, geringe Abweichungen möglich
Unbalance g·mm are reference values, little variances possible

WUCHTSCHRAUBENSATZ SET OF BALANCING SCREWS



Zum Feinwuchten von Werkzeugaufnahmen mit Wuchtgewinden M 6 (z.B. Schrumpffutter von HAIMER).

For fine-balancing of all tool holders with balancing threads M 6 (e.g. shrink fit chucks from HAIMER).

Die Wuchtschrauben haben verschiedene Gewichte in einer feinen Abstufung. Sie werden in die vorhandenen Wuchtgewinde des Futter gedreht, so dass ihr Gewicht die Unwucht des Futter ausgleicht.

The screws have different weights in a fine graduation. They are screwed into the balancing threads of the tool holder so that their weight compensates the unbalance of the tool holder.

- Sortiment mit 11 verschiedenen Schraubengrößen mit verschiedenen Gewichten
- Die Schrauben werden bis auf den Grund des Gewindes gedreht und festgezogen. Keine Schraubensicherung notwendig.
- Schnell und präzise auswuchten
- Keine Beschädigung der Werkzeugaufnahme
- Beliebig oft wiederholbar
- Passend für alle Fabrikate
- Die Auswuchtmaschine berechnet das benötigte Gewicht (z.B. HAIMER Tool Dynamic)

- Set consisting of screws of 11 different sizes and weights
- Screws are screwed to the ground of the thread and tightened. No additional fixing of screws necessary.
- Balancing quickly and precisely
- No damage of tool holders
- Can be repeated as often as necessary
- Suitable for tool holders of all brands
- The balancing machine calculates the necessary weight of the screws (e.g. HAIMER Tool Dynamic)

- Lieferumfang: Kassette mit 11 x 10 Wuchtschrauben, Schraubendreher

- Included in delivery: Case with 11 x 10 balancing screws, screw driver

Wuchtschraubensatz/Set of balancing screws

Bestell-Nr./Order No. 80.203.00

SCHWERMETALLWUCHTSCHRAUBEN HEAVY METAL BALANCING SCREWS

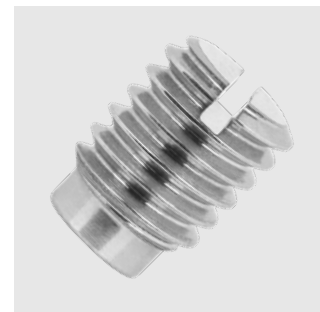
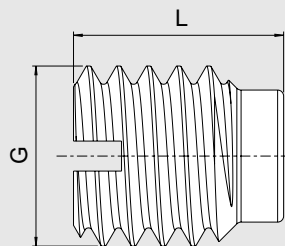

Schwermetallwuchtschrauben (Gewinde M6) zum manuellen Auswuchten von Werkzeugaufnahmen.

Heavy metal balancing screws (thread M6) for manual balancing of tool holders.

Maß/Length L [mm]	07	07	08	08	10	10
Größe/Size G [mm]	M6x7	M6x7 (5 Stk./5 pcs.)	M6x8	M6x8 (5 Stk./5 pcs.)	M6x10	M6x10 (5 Stk./5 pcs.)
Masse/Mass	ca. 2,3g	ca. 2,3g	ca. 2,7g	ca. 2,7g	ca. 3,5g	ca. 3,5g
Bestell-Nr./Order No. 85.502...	.7.0	.7.0.SET	.8.0	.8.0.SET	.10.0	.10.0.SET

EINSTELLSCHRAUBEN FÜR SCHRUMPFUTTER BACK UP SCREWS FOR SHRINK FIT CHUCKS

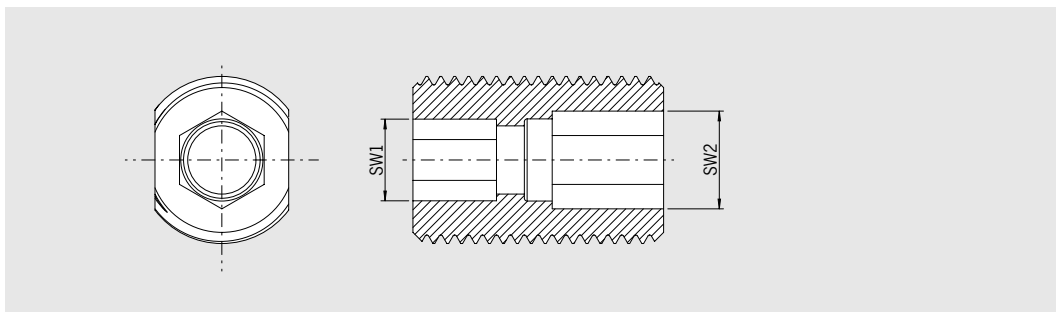

- Innensechskant an jedem Ende – immer zugänglich
- Seitlich abgeflacht für optimalen Kühlmittelabfluss
- Feingewinde für höchste Genauigkeit

- Hexagon socket on each end – can always be reached
- Flats on sides for optimized coolant drainage
- Fine thread for maximum accuracy

[mm]	Typ/Type	SK40/50 BT40/50	HSK-A32/E32 A40/E40	HSK-A50/ E50	HSK-A63	HSK-F63	HSK-A80	HSK-A100
Spann-Ø Clamping Ø	Länge/Length Bestell-Nr. Order No. 85.810...							
6		.12.1	.12.1	.12.1	.12.1	.12.1	.12.1	.12.1
8		.15.1	.15.1	.15.1	.15.1	.15.1	.15.1	.15.1
10	kurz/short andere/other	.18.2 .18.2	.18.2 .36.2	.18.2 .36.2	.18.2 .36.2	.18.2 .36.2	.18.2 .36.2	.18.2 .36.2
12	kurz/short andere/other	.24.2 .24.2	.24.2 .24.2	.39.2 .24.2	.39.2 .24.2	.39.2 .24.2	.21.2 .24.2	.21.2 .24.2
14	kurz/short ZG130/oversize	.24.2 .24.2	.24.2 .24.2	.39.2 .24.2	.39.2 .24.2	— —	.21.2 .24.2	.21.2 .24.2
16	kurz/short ZG130/oversize	.46.2 .46.2	.27.2 .27.2	.25.2 .38.2	.25.2 .46.2	.25.2 ¹⁾ .46.2 ¹⁾	.27.2 .46.2	.40.1 .46.2
18	kurz/short ZG130/oversize	.46.2 .46.2	— —	.25.2 .38.2	.25.2 .46.2	— —	.27.2 .46.2	.40.1 .46.2
20	kurz/short ZG130/oversize	.52.2 .52.2	— —	.51.2 .52.2	.51.2 .52.2	.51.2 ¹⁾ .52.2 ¹⁾	.51.2 .52.2	.51.2 .52.2
25	kurz/short ZG130/oversize	.52.2 .52.2	— —	— —	.52.2 .52.2	.52.2 ¹⁾ .52.2 ¹⁾	.52.2 .52.2	.52.2 .52.2
32	kurz/short ZG130/oversize	.52.2 .52.2	— —	— —	.52.2 .52.2	— —	.52.2 .52.2	.52.2 .52.2

Bestell-Nr./Order No.	SW1	SW2	Gewinde/Thread
85.810.12.1	SW2,5	SW2,5	M5x0,8x16
85.810.15.1	SW3	SW3	M6x1x16
85.810.18.2	SW3	SW4	M8x1x16
85.810.24.2	SW4	SW5	M10x1x20
85.810.25.2	SW5	SW6	M12x1x18
85.810.27.2	SW4	SW6	M12x1x18
85.810.36.2	SW3	SW4	M8x1x20
85.810.46.2	SW6	SW6	M12x1x20

Bestell-Nr./Order No.	SW1	SW2	Gewinde/Thread
85.810.21.2	SW4	SW5	M10x1x16
85.810.38.2	SW5	SW6	M12x1x22
85.810.39.2	SW4	SW5	M10x1x18
85.810.40.1	SW6	SW6	M12x1x16
85.810.51.2	SW5	SW8	M16x1x18
85.810.52.2	SW6	SW8	M16x1x22

1) Nur durch Spannbohrung einstellbar
Only adjustable through clamping bore

LANGE EINSTELLSCHRAUBEN FÜR SCHRUMPFUTTER BACK UP SCREWS LONG FOR SHRINK FIT CHUCKS

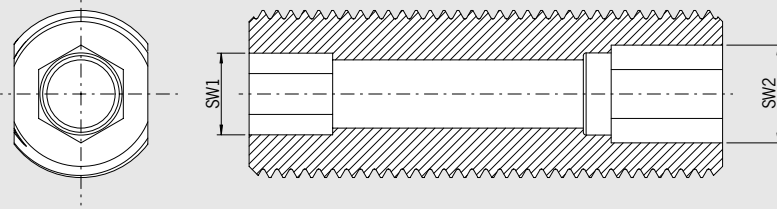

- Innensechskant an jedem Ende – immer zugänglich
- Seitlich abgeflacht für optimalen Kühlmittelabfluss
- Feingewinde für höchste Genauigkeit

- Hexagon socket on each end – can always be reached
- Flats on sides for optimized coolant drainage
- Fine thread for maximum accuracy

[mm]	Typ/Type	SK40/50 BT40/50	HSK-A32/E32 A40/E40	HSK-A50/ E50	HSK-A63	HSK-F63	HSK-A80	HSK-A100
Spann-Ø Clamping Ø	Länge/Length Bestell-Nr. Order No. 85.810...							
6		.12.4	.12.4	.12.4	.12.4	.12.4	.12.4	.12.4
8		.15.4	.15.4	.15.4	.15.4	.15.4	.15.4	.15.4
10		.18.4	.18.4	.18.4	.18.4	.18.4	.18.4	.18.4
12		.21.4	.21.4	.21.4	.21.4	.21.4	.21.4	.21.4
14		.21.4	.21.4	.21.4	.21.4	.21.4	.21.4	.21.4
16	kurz/short ZG130/oversize	.37.4 .37.4	.27.4 .27.4	.25.4 .25.4	.25.4 .37.4	.25.4 ¹⁾ .37.4 ¹⁾	.27.4 .37.4	.40.4 .37.4
18	kurz/short ZG130/oversize	.37.4 .37.4	— —	.25.4 .25.4	.25.4 .37.4	.25.4 ¹⁾ .37.4 ¹⁾	.27.4 .37.4	.40.4 .37.4
20	kurz/short ZG130/oversize	.52.4 .52.4	— —	.52.4 .52.4	.52.4 .52.4	.52.4 ¹⁾ .52.4 ¹⁾	.52.4 .52.4	.52.4 .52.4
25		.52.4	—	—	.52.4	.52.4 ¹⁾	.52.4	.52.4
32		.52.4	—	—	.52.4	.52.4 ¹⁾	.52.4	.52.4

Bestell-Nr./Order No.	SW1	SW2	Gewinde/Thread
85.810.12.4	SW2,5	SW2,5	M5x0,8x24
85.810.15.4	SW3	SW3	M6x1x24
85.810.18.4	SW3	SW4	M8x1x24
85.810.21.4	SW4	SW5	M10x1x28
85.810.25.4	SW5	SW6	M12x1x34
85.810.27.4	SW4	SW6	M12x1x34
85.810.37.4	SW6	SW8	M12x1x34
85.810.52.4	SW6	SW8	M16x1x34

1) Nur durch Spannbohrung einstellbar
Only adjustable through clamping bore

EINSTELLSCHRAUBEN FÜR POWER SHRINK CHUCKS BACK UP SCREWS FOR POWER SHRINK CHUCKS

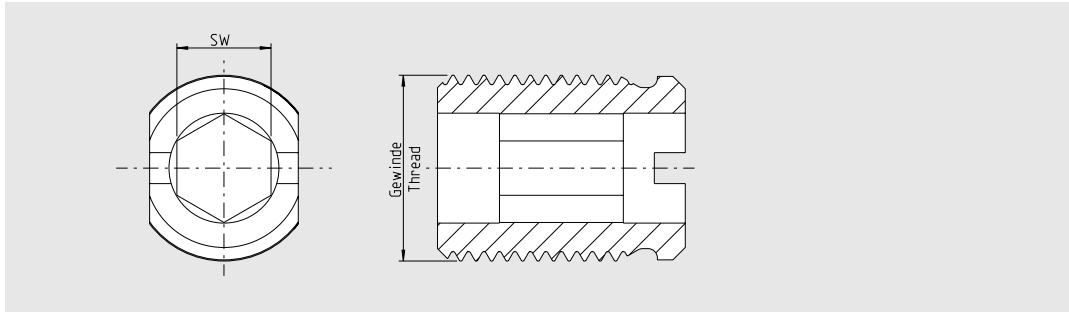

- Optimiert für Schrumpffutter mit Cool Jet
- Garantierte Kühlmittelzufuhr über Quernut
- Innensechskant an jedem Ende – immer zugänglich
- Seitlich abgeflacht für optimalen Kühlmittelabfluss
- Feingewinde für höchste Genauigkeit

- Optimised for Shrink Fit Chucks with Cool Jet
- Guaranteed coolant supply via transverse groove
- Hexagon socket on each end – can always be reached
- Flats on sides for optimized coolant drainage
- Fine thread for maximum accuracy

[mm]	Typ/Type	SK40/50 BT40/50	HSK-A32/E32 A40/E40	HSK-A50/ E50	HSK-A63	HSK-F63	HSK-A80	HSK-A100
Spann-Ø Clamping Ø	Länge/Length Bestell-Nr. Order No.							
6	85.810...	.12.3	.12.3	.12.3	.12.3	.12.3	.12.3	.12.3
8		.15.3	.15.3	.15.3	.15.3	.15.3	.15.3	.15.3
10		.18.3	.18.3	.18.3	.18.3	.18.3	.18.3	.18.3
12	ultrakurz/ultrashort	.48.3 .48.3.1	.48.3 —	.48.3 —	.48.3 —	.48.3 —	.48.3 —	.48.3 —
14		.21.3	.21.3	.21.3	.21.3	—	.21.3	.21.3
16	ultrakurz/ultrashort	.49.3 .49.3.1	.49.3 —	.49.3 —	.49.3 —	.49.3 —	.49.3 —	.49.3 —
18		.40.3	—	.40.3	.40.3	—	.40.3	.40.3
20		.51.3	—	.51.3	.51.3	.51.3	.51.3	.51.3
25		.52.3	—	—	.52.3	—	.52.3	.52.3
32		.52.3	—	—	.52.3	—	.52.3	.52.3

Bestell-Nr./Order No.	SW	Gewinde/Thread
85.810.12.3	SW2,5	M5x0,8x16
85.810.15.3	SW3	M6x1x16
85.810.18.3	SW4	M8x1x16
85.810.21.3	SW5	M10x1x16
85.810.40.3	SW6	M12x1x16
85.810.43.3	SW6	M12x1x18
85.810.46.3	SW6	M12x1x20
85.810.48.3	SW5	M10x1x16

Bestell-Nr./Order No.	SW	Gewinde/Thread
85.810.48.3.1	SW5	M10x1x28
85.810.49.3	SW6	M12x1x16
85.810.49.3.1	SW6	M12x1x20
85.810.51.3	SW6	M16x1x18
85.810.52.3	SW6	M16x1x20

EINSTELLSCHRAUBEN FÜR WHISTLE-NOTCH BACK UP SCREWS FOR WHISTLE NOTCH

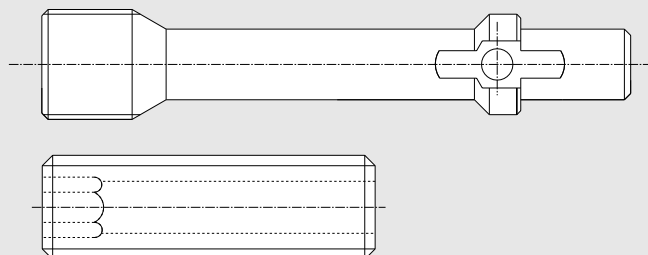

Größe/Size Ø D1 [mm]		DIN 69871, SK40	DIN 69871, SK50	JIS B 6339, BT40	JIS B 6339, BT50	DIN 69893, HSK-A63, HSK-A80, HSK-A100
6	kurz/short	85.150.01	85.150.03	85.150.01	85.150.03	85.810.12.1
6	lang/long	85.150.04	85.150.04	85.150.04	85.150.04	85.810.12.1
6	ZG 130	85.150.05	85.150.05	—	—	—
6	überlang/oversize	85.150.07	85.150.07	85.150.07	85.150.07	85.810.12.1
8	kurz/short	85.150.01	85.150.03	85.150.01	85.150.03	85.810.15.1
8	lang/long	85.150.04	85.150.04	85.150.04	85.150.04	85.810.15.1
8	ZG 130	85.150.05	85.150.05	—	—	—
8	überlang/oversize	85.150.07	85.150.07	85.150.07	85.150.07	85.810.15.1
10	kurz/short	85.150.01	85.150.03	85.150.02	85.150.03	85.810.18.2
10	lang/long	85.150.04	85.150.04	85.150.04	85.150.04	85.810.18.2
10	ZG 130	85.150.05	85.150.05	—	—	—
10	überlang/oversize	85.150.07	85.150.07	85.150.07	85.150.07	85.810.36.2
12	kurz/short	85.150.01	85.150.01	85.150.01	85.150.02	85.810.24.2
12	lang/long	85.150.04	85.150.04	85.150.04	85.150.04	85.810.24.2
12	ZG 130	85.150.05	85.150.05	—	—	—
12	überlang/oversize	85.150.06	85.150.07	85.150.06	85.150.07	85.810.24.2
14	kurz/short	85.150.01	85.150.01	85.150.01	85.150.02	85.810.24.2
14	lang/long	85.150.04	85.150.04	85.150.04	85.150.04	85.810.24.2
14	ZG 130	85.150.05	85.150.05	—	—	—
14	überlang/oversize	85.150.06	85.150.06	85.150.06	85.150.07	85.810.24.2
16	kurz/short	85.150.01	85.150.01	85.150.01	85.150.02	85.810.46.2
16	lang/long	85.150.04	85.150.04	85.150.04	85.150.04	85.810.46.2
16	ZG 130	85.150.05	85.150.05	—	—	—
16	überlang/oversize	85.150.07	85.150.06	85.150.06	85.150.06	85.810.46.2
18	kurz/short	85.150.01	85.150.01	85.150.01	85.150.02	85.810.46.2
18	lang/long	85.150.04	85.150.04	85.150.04	85.150.04	85.810.46.2
18	ZG 130	85.150.05	85.150.05	—	—	—
18	überlang/oversize	85.150.07	85.150.06	85.150.06	85.150.06	85.810.46.2
20	kurz/short	85.150.01	85.150.01	85.150.01	85.150.02	85.810.38.2
20	lang/long	85.150.04	85.150.04	85.150.04	85.150.04	85.810.38.2
20	ZG 130	85.150.05	85.150.05	—	—	—
20	überlang/oversize	85.150.07	85.150.06	85.150.06	85.150.06	85.810.38.2
25	kurz/short	85.150.03	85.150.02	85.150.03	85.150.03	85.810.38.2
25	lang/long	—	—	—	—	85.810.38.2
25	ZG 130	85.150.08	85.150.08	—	—	—
25	überlang/oversize	85.150.06	85.150.06	85.150.06	85.150.06	85.810.38.2
32	kurz/short	—	85.150.03	85.150.03	85.150.03	85.810.38.2
32	lang/long	—	—	—	—	85.810.38.2
32	ZG 130	—	85.150.08	—	—	—
32	überlang/oversize	—	85.150.06	85.150.06	85.150.06	85.810.38.2
40	kurz/short	—	85.150.02	—	85.150.03	—
40	lang/long	—	—	—	—	—
40	ZG 130	—	85.150.08	—	—	—
40	überlang/oversize	—	85.150.05	—	85.150.05	—

LÄNGENEINSTELLSCHRAUBEN FÜR SPANZANGENFUTTER ER BACK UP SCREWS FOR COLLET CHUCKS

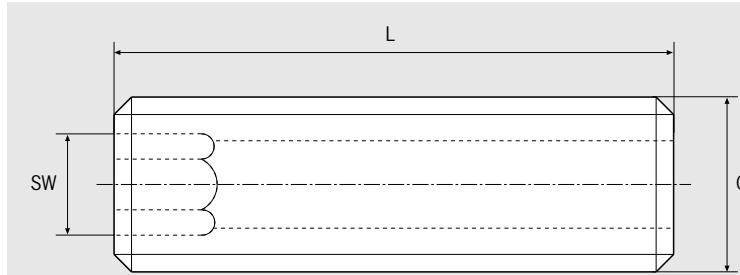

Größe/Size Ø [mm]	HSK-32, 40, 50, 63, 80, 100	SW	L [mm]	Gewinde/Thread
ER 16	Bestell-Nr./Order No. 85.800.34	3	25	M6
ER 20	85.800.34	3	25	M6
ER 25	85.800.34	3	25	M6
ER 32	85.800.35	5	25	M10
ER 40	85.800.35	5	25	M10

VORSPANNFEDERN FÜR SCHRUMPFUTTER TENSION SPRINGS FOR SHRINK FIT CHUCKS

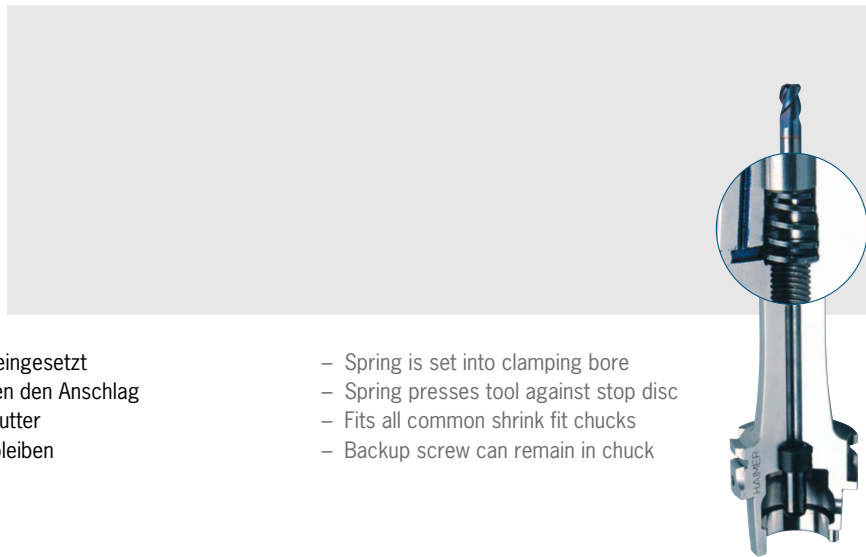

- Feder wird in die Spannbohrung eingesetzt
- Feder drückt das Werkzeug gegen den Anschlag
- Passt in alle gängigen Schrumpffutter
- Einstellschraube kann im Futter bleiben

- Spring is set into clamping bore
- Spring presses tool against stop disc
- Fits all common shrink fit chucks
- Backup screw can remain in chuck

Vorspannfeder für Längeneinstellung
Tension spring for length presetting

	Bestell-Nr./Order No.									
Vorspannfeder/Tension spring	Ø 6	Ø 8	Ø 10	Ø 12	Ø 14	Ø 16	Ø 18	Ø 20	Ø 25	Ø 32
Bestell-Nr./Order No. 85.830...	.06	.08	.10	.12	.14	.16	.18	.20	.25	.32
Vorspannfeder Set bestehend aus 10 Stk. je Größe inkl. Ausziehgreifer/Tension spring set (10 pcs. of each size) incl. grab	85.830.00									

SPANNSCHRAUBEN FÜR WELDON UND WHISTLE-NOTCH AUFNAHMEN CLAMPING SCREWS FOR WELDON AND WHISTLE NOTCH

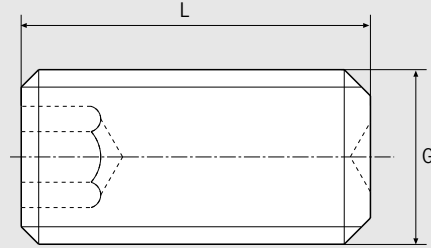

Spann/Clamping	Ø D1 [mm]	06	08	10	12	14	16	18	20	25	25	32	40
Bestell-Nr./Order No. 85.100...		.06	.08	.10	.12	.12	.14	.14	.16	.18	ultrakurz ultra short	.20	.20
G		M6	M8	M10	M12	M12	M14	M14	M16	M18x2	M18x2	M20x2	M20x2
L		10	10	12	16	16	16	16	16	20	13	20	20

SPANNSCHRAUBEN FÜR HG-FUTTER CLAMPING SCREWS FOR HG CHUCK

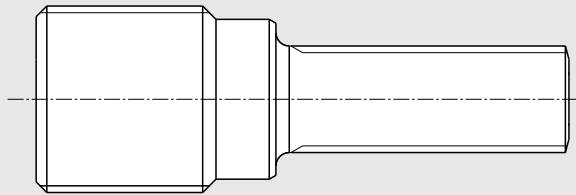

	DIN 69871 SK 40	DIN 69871 SK 50	MAS BT 40	MAS BT 50	HSK-A63	HSK-F63	HSK-A80	HSK-A100
für Maß/for length kurz/short	40.420.01	50.420.01	40.620.01	—	A63.120.01	F63.120.01	A80.120.01	A10.120.01
Bestell-Nr./Order No. 82.560...	.03	.03	.03	—	.02	.02	.02	.02
für Maß/for length kurz/short	40.420.02	50.420.02	40.620.02	—	A63.120.02	F63.120.02	A80.120.02	A10.120.02
Bestell-Nr./Order No. 82.560...	.02	.02	.02	—	.14	.14	.14	.14
für Maß/for length kurz/short	40.420.03	50.420.03	40.620.03	—	A63.120.03	F63.120.03	A80.120.03	A10.120.03
Bestell-Nr./Order No. 82.560...	.02	.02	.02	—	.14	.14	.14	.14
für Maß/for length lang/long	40.421.01	50.421.01	40.621.01	50.621.01	—	—	—	—
Bestell-Nr./Order No. 82.560...	.04	.04	.04	.04	—	—	—	—
für Maß/for length lang/long	40.421.02	50.421.02	40.621.02	50.621.02	—	—	—	—
Bestell-Nr./Order No. 82.560...	.01	.01	.01	.01	—	—	—	—
für Maß/for length lang/long	40.421.03	50.421.03	40.621.03	50.621.03	—	—	—	—
Bestell-Nr./Order No. 82.560...	.05	.05	.05	.17	—	—	—	—
für Maß/for length überlang/extralong	40.422.01	50.422.01	40.622.01	50.622.01	A63.122.01	—	A80.122.01	A10.122.01
Bestell-Nr./Order No. 82.560...	.08	.08	.08	.08	.04	—	.04	.04
für Maß/for length überlang/extralong	40.422.02	50.422.02	40.622.02	50.622.02	A63.122.02	—	A80.122.02	A10.122.02
Bestell-Nr./Order No. 82.560...	.06	.06	.06	.06	.01	—	.05	.05
für Maß/for length überlang/extralong	40.422.03	50.422.03	40.622.03	50.622.03	A63.122.03	—	A80.122.03	A10.122.03
Bestell-Nr./Order No. 82.560...	.07	.07	.07	.07	.01	—	.05	.05

SCHNELLWECHSELEINSÄTZE TYP FH QUICK CHANGE INSERTS TYPE FH

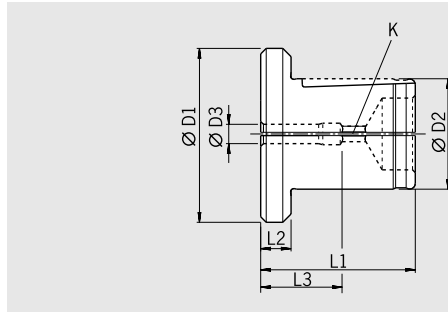

Nicht kompatibel mit Fa. Bilz/Not compatible with comp. Bilz

Typ FH/Type FH					01	03		
Ø D1 [mm]					32	42		
Ø D2 [mm]					20	28		
L1 [mm]					28	35		
L2 [mm]					5,5	5,5		
Schneidebereich/Cutting range					M3-M14	M4,5-M24		
Schaft/Shank Ø D3	Vierkant K Square K	DIN 371	DIN 374/376 ISO	Schaftmaß Shank size	L3	Bestell-Nr. Order No.	L3	Bestell-Nr. Order No.
2,5	2,1	M1-M1,8	M3,5	—	11,5	80.501.02.5	—	—
2,8	2,1	M2-M2,5	M4	—	12	80.501.02.8	—	—
3,15	2,5	M3	M4,5-M5	M4-M3	13	80.501.03.1	—	—
3,5	2,7	M3	M4,5-M5	—	14,5	80.501.03.5	—	—
3,55	2,8	M3	M4,5-M5	M4,5-M3,5	14	80.501.03.6	—	—
4	3	M3,5	—	—	16	80.501.04.0	—	—
4	3,15	M3,5	—	M4-M5	16	80.501.04.3	—	—
4,5	3,4	M4	M6	—	17	80.501.04.5	—	—
5	4	M4	M6	M5	17	80.501.05.0	—	—
6	4,9	M4,5-M6	M8	—	17	80.501.06.0	17	80.503.06.0
6,3	5	M4,5-M6	M8	M6-M8	17	80.501.06.3	17	80.503.06.3
7	5,55	M7	M10	—	17	80.501.07.0	17	80.503.07.0
8	6,3	M8	—	—	17	80.501.08.0	20	80.503.08.0
9	7,1	—	M12	—	17	80.501.09.0	21	80.503.09.0
10	8	M10	—	—	17	80.501.10.0	21	80.503.10.0
11	9	—	M14	—	17	80.501.11.0	21	80.503.11.0
11,2	9	—	—	—	—	—	21	80.503.11.2
12	9	—	M16	—	—	—	21	80.503.12.0
12,5	10	—	M16	M16	—	—	21	80.503.12.5
14	11	—	M18	—	—	—	22	80.503.14.0
14	11,2	—	M18	M18-M20	—	—	22	80.503.14.2
16	12	—	M20	—	—	—	22	80.503.16.0
16	12,5	—	M20	M22	—	—	22	80.503.16.5
18	14,5	—	M22-M24	—	—	—	22	80.503.18.0

MESSERKOPF-, KOMBI-ZUBEHÖR ACCESSORIES FACE MILL AND COMBINATION ARBORS

MITNEHMERRINGE/DRIVING RINGS

Aufnahme-Ø/Tool holder Ø	16	22	27	32	40	50
Ø D [mm]	32	40	48	58	70	90
L [mm]	10	12	12	14	14	16
Bestell-Nr./Order No. 85.200...	.16	.22	.27	.32	.40	.50

Mitnehmerringe für DIN 6366/1 für Kombiaufsteckfräserdorne

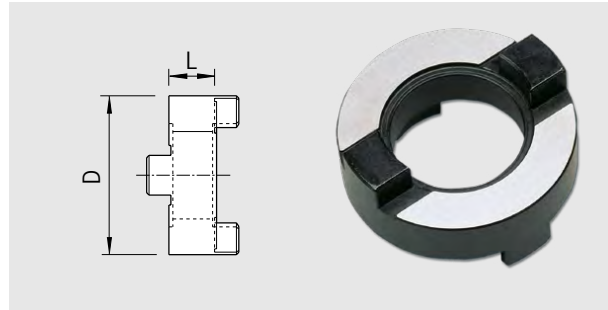

Driving rings DIN 6366/1 for combination shell end mill adapters

FRÄSERANZUGSSCHRAUBEN TIGHTENING BOLTS

Aufnahme-Ø/Tool holder Ø	16	22	27	32	40	50	60
Ø D [mm]	20	28	35	42	52	63	75
L [mm]	22	25	30	35	40	48	59
G	M8	M10	M12	M16	M20	M24	M30
Bestell-Nr./Order No. 85.300...	.16	.22	.27	.32	.40	.50	.60

Fräseranzugsschrauben DIN 6367 für Kombiaufsteckfräserdorne und Messerkopfaufnahmen

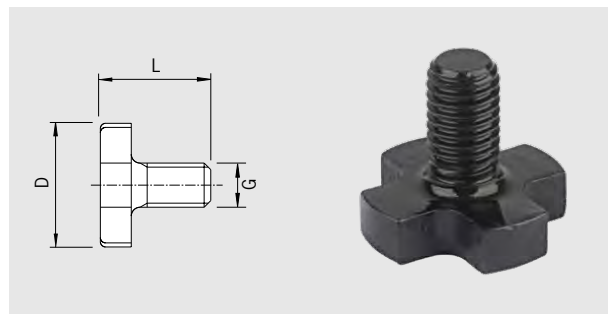

Tightening bolts DIN 6367 for combination shell end mill adapters and face mill arbors

PASSFEDERN/FEATHER KEYS

Aufnahme-Ø/Tool holder Ø	16	22	27	32	40	50
L [mm]	20	25	25	28	32	36
B [mm]	4	6	7	8	10	12
Bestell-Nr./Order No. 85.400...	.16	.22	.27	.32	.40	.50

Passfedern DIN 6885 mit Abdrückschraube für Kombiaufsteckfräserdorne

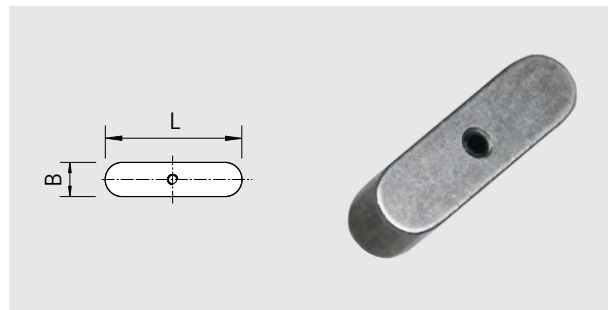

Feather keys DIN 6885 with loosening screw for combination shell end mill adapters

UMRÜSTSATZ AD-AF CONVERSION KIT AD-AF

Größe/Size	SK40	SK50
Bestell-Nr./Order No. 85.600...	.40	.50

Umrüstsatz Form AD/Form AF je 50 Dichtdübel und Spanschrauben

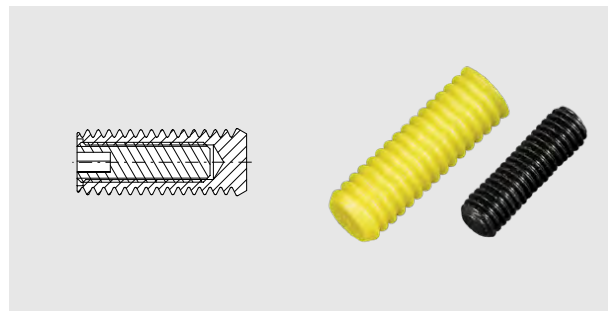

Conversion kit form AD/form AF comprising each 50 sealing dowels and lock screws

KEGELWISCHER CONE WIPER

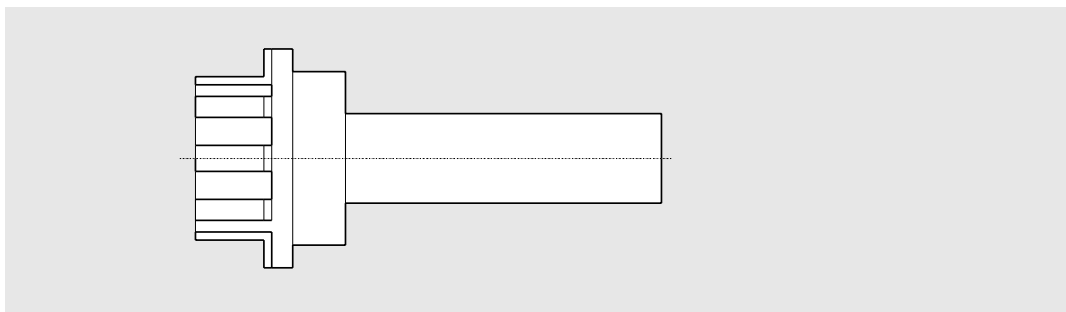

Kegelwischer/Cone wiper HSK	HSK-25	HSK-32	HSK-40	HSK-50	HSK-63	HSK-80	HSK-100	HSK-125
Bestell-Nr./Order No. 85.820...	.25	.32	.40	.50	.63	.80	.10	.125

Zum Reinigen des Innenkegels von HSK-Aufnahmen, Spindeln oder Adaptern./For cleaning inner taper of HSK-Chucks, spindles or adapters.

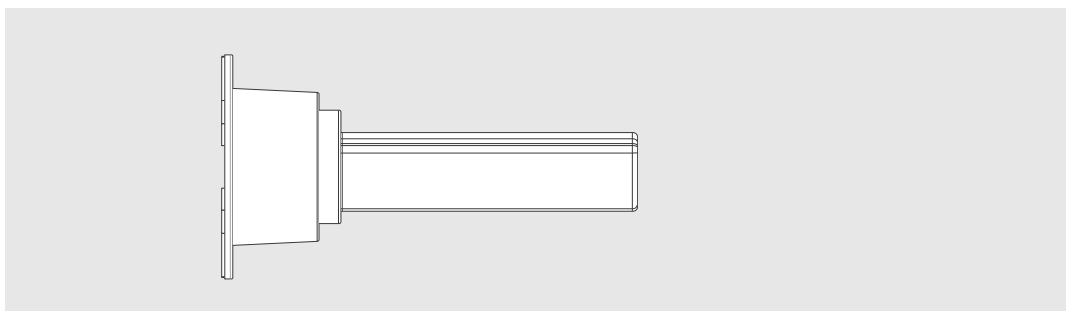
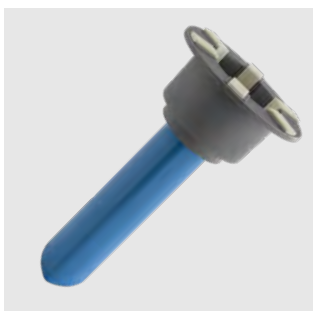

Kegelwischer – Außen/Cone wiper – Outside HSK	HSK-40	HSK-50	HSK-63	HSK-80	HSK-100
Bestell-Nr./Order No. 85.821...	.40	.50	.63	.80	.10

Zum Reinigen des Außenkegels von HSK Aufnahmen./For cleaning the outer cone of HSK chucks.

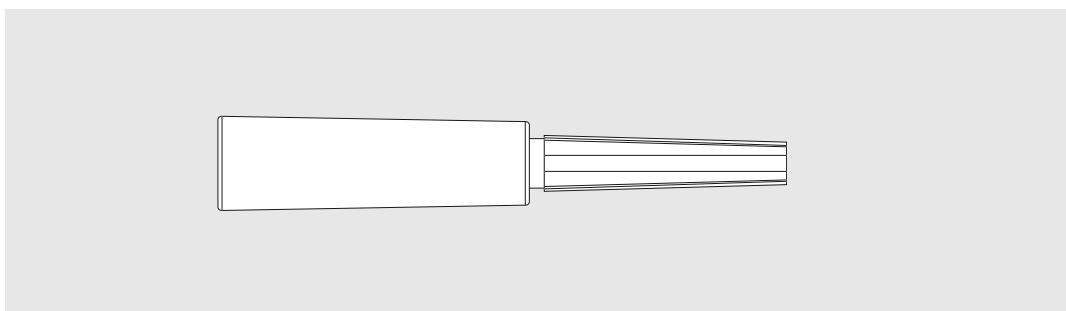

Kegelwischer/Cone wiper MK	MK 01	MK 02	MK 03	MK 04
Bestell-Nr./Order No. 86.100...	.01	.02	.03	.04

Zum Reinigen des Innenkegels von MK-Aufnahmen, Spindeln oder Adaptern./For cleaning inner taper of MK-Chucks, spindles or adapters.

KEGELWISCHER CONE WIPER

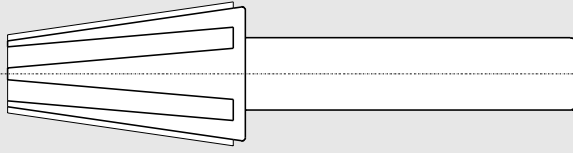

Kegelwischer/Cone wiper SK, BT, CAT	SK30	BT30	SK40	BT40	CAT40	SK50	BT50	CAT50
Bestell-Nr./Order No. 86.100...	.30	.30	.40	.40	.40	.50	.50	.50

Zum Reinigen des Innenkegels von SK/BT/CAT-Aufnahmen, Spindeln oder Adaptern./For cleaning inner taper of SK/BT/CAT-Chucks, spindles or adapters.



Zylindrischer Wischer/Cylindrical wiper Ø [mm]	06	08	10	12	14	16	18	20	25	32
Bestell-Nr./Order No. 86.201...	.06	.08	.10	.12	.14	.16	.18	.20	.25	.32

Zum Reinigen von zylindrischen Spannbohrungen./For cleaning cylindrical clamping bores.

KEGELWISCHER CONE WIPER

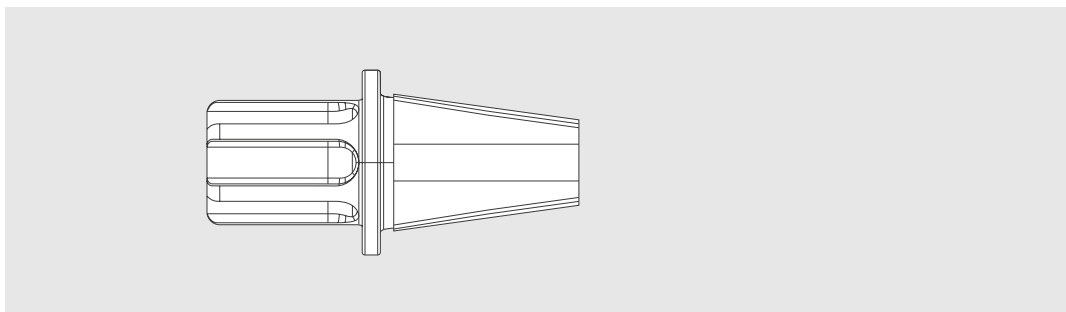

Kegelwischer/Cone wiper ER	ER 11	ER 16	ER 20	ER 25	ER 32
Bestell-Nr./Order No. 86.100...	.ER11	.ER16	.ER20	ER25	ER32

Zum Reinigen des Innenkegels von ER-Aufnahmen, Spindeln oder Adaptern./For cleaning the inner taper of ER-Chucks, spindles or adapters.

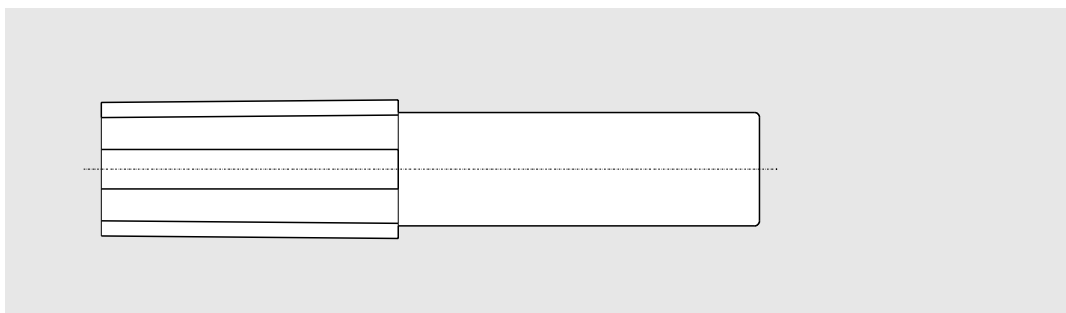

Kegelwischer/Cone wiper HG	HG 01	HG 02	HG 03
Bestell-Nr./Order No. 82.590...	.01	.02	.03

Zum Reinigen des Innenkegels von HG-Aufnahmen./For cleaning the inner taper of HG-chucks.

UMRÜSTSATZ DIN 2080 – DIN 69871

CONVERSION KIT DIN 2080 – DIN 69871

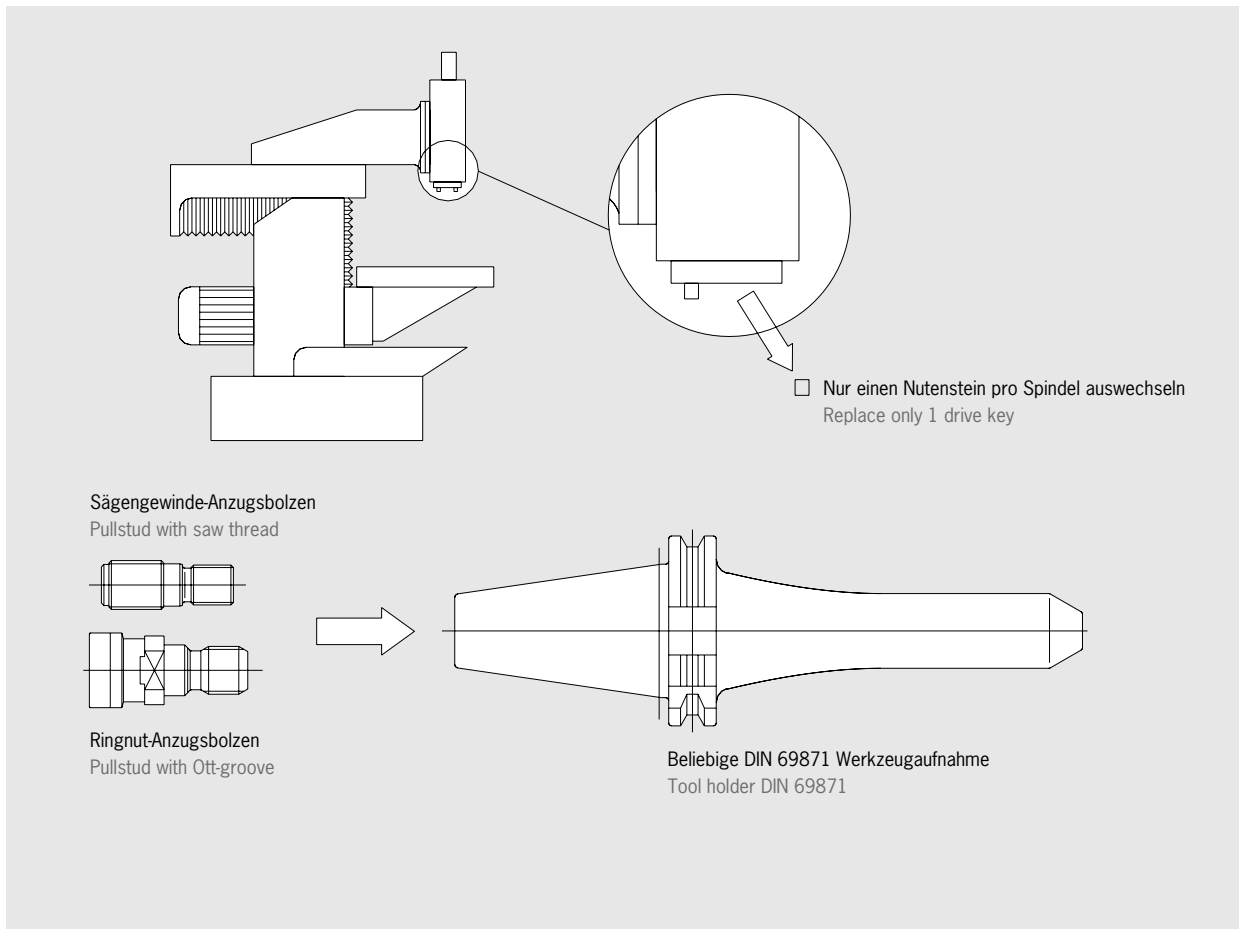

Zum Umrüsten von Spindeln DIN 2080 für Werkzeugaufnahmen DIN 69871/For conversion of spindles DIN 2080 for tool holders DIN 69871



2 Austauschnutensteine mit Befestigungsschrauben
 2 drive keys with clamping screws

SK 40: Bestell-Nr./Order No. 85.500.40

SK 50: Bestell-Nr./Order No. 85.500.50