

## Broaching Unit

The new state of the art broaching unit for economic manufacturing of oriented keyways and splines.

Faster return on investment.



In operation:



# Broaching Unit – for ID and OD

Same insert holder for ID and OD broaching by rotating 180 degrees

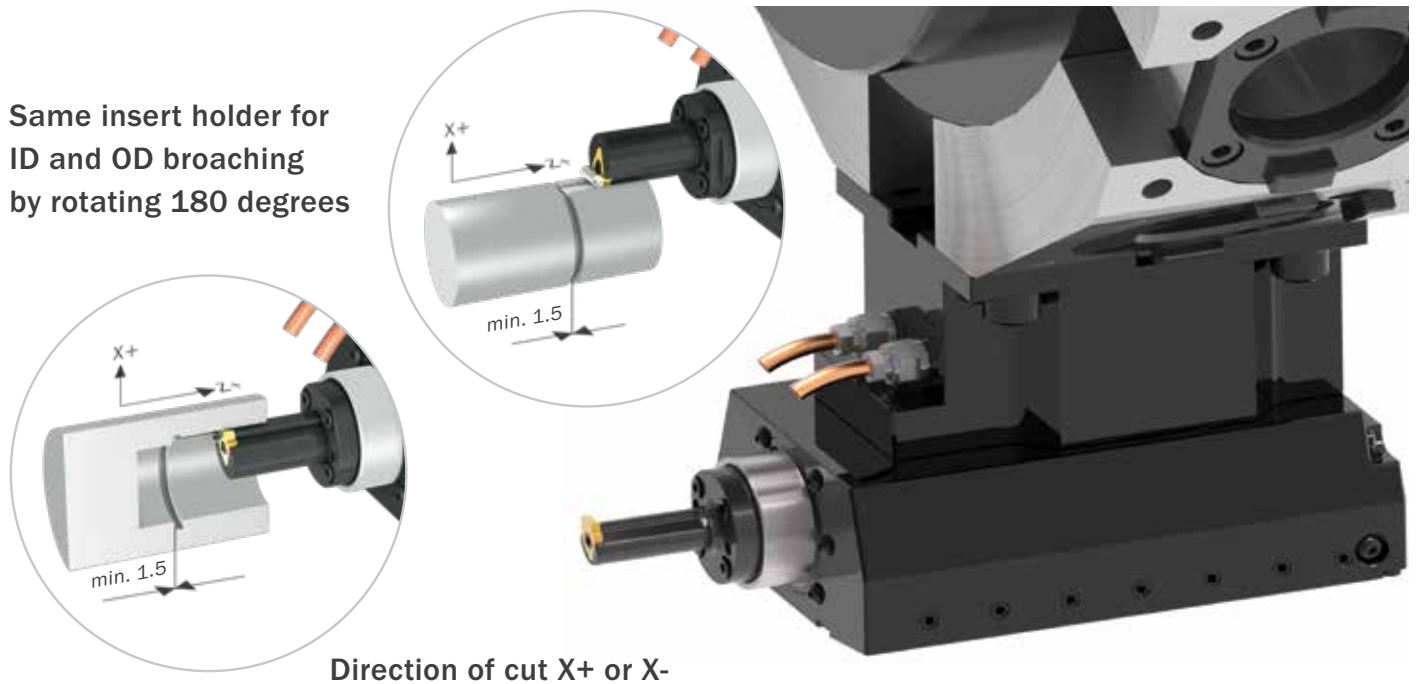

## Function

1  
Position insert on Z



3  
Cutter lifts from workpiece



2  
Cutter drives into workpiece



4  
Lift-off function prevents wear/breakage when cutter retracts



## Sample workpieces

Keyway



Internal involute spline according to DIN 5482



External involute spline according to DIN 5480

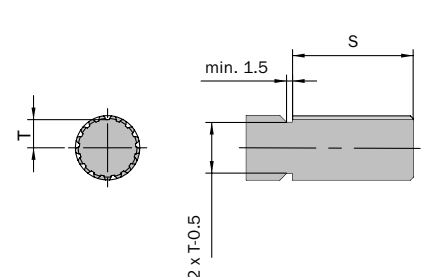
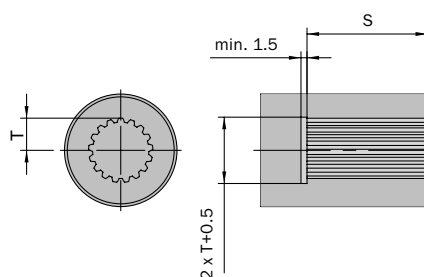
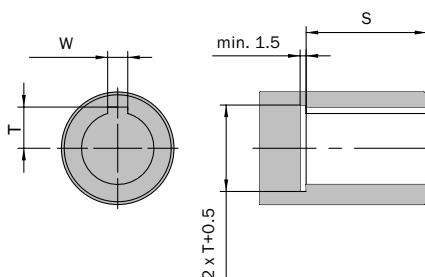

## Broaching Unit — OD mounted



Type 26 / 32 / 52

## Broaching Unit — Face mounted



Type 32 / 52

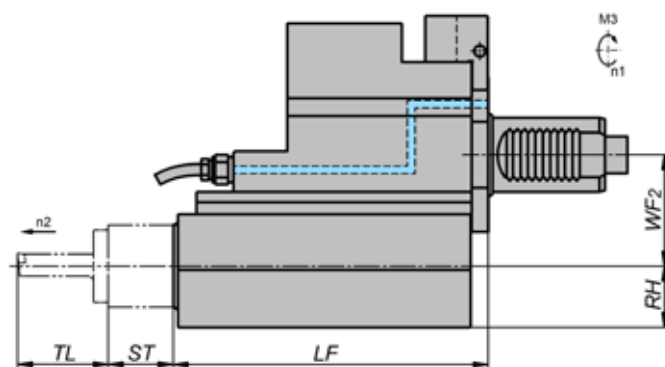
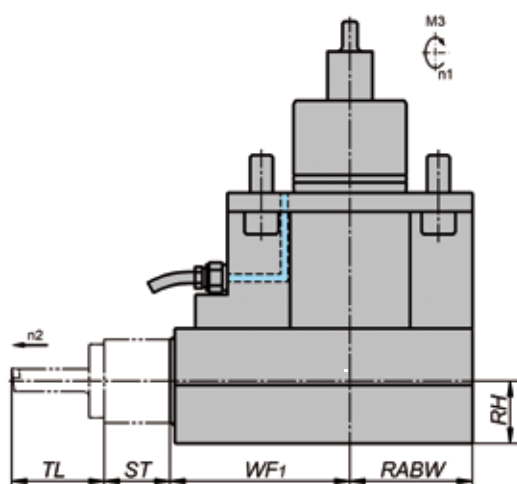

Type	Working stroke (S)	Total stroke	Max. groove width (W)	Workpiece material [N/mm <sup>2</sup> ]	Max. strokes [1/min] (n2)	Ratio	Max. feed per stroke
26	26	28	6	1200	1500	2:1	0.15
32	32	35	12	1200	1000	1:1	0.15
52	52	55	12	1200	800	1:1	0.15

Type	TL	ST	LF	WF1	WF2	RABW	RH
26	38	28	-	59	-	61	30.5
32	49	35	170	95.5	60	65	33
52	67	55	180	105.5	65	74	33

Dimensions in mm

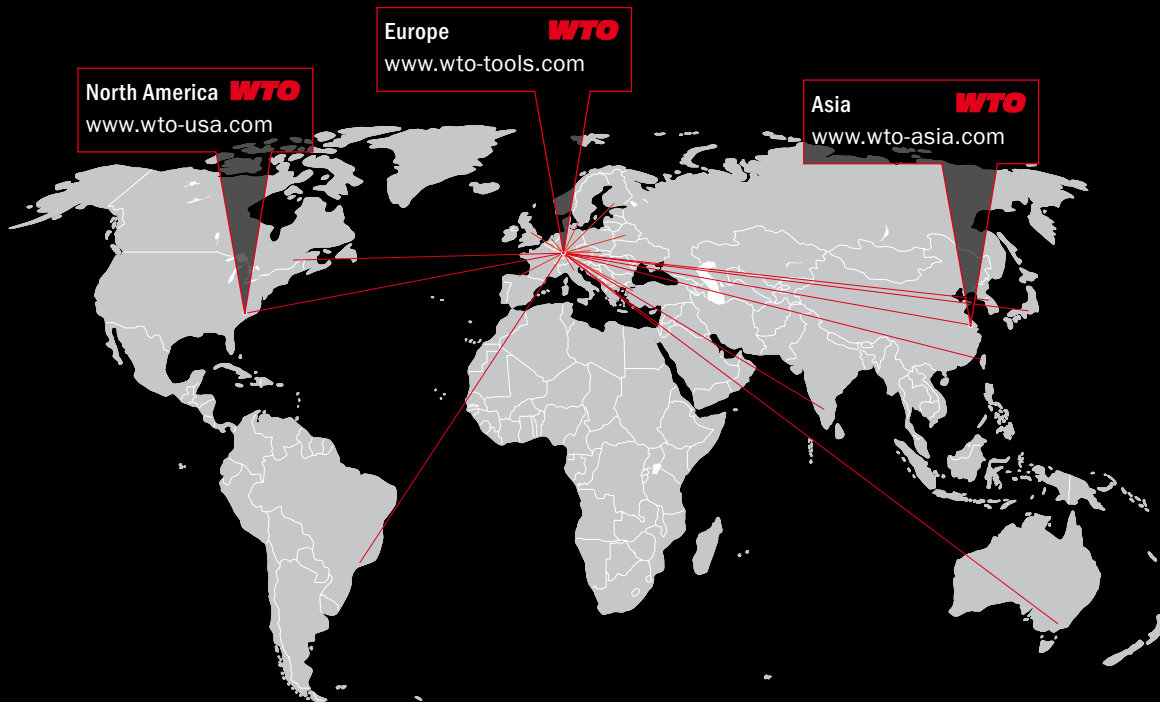

WTO Werkzeug-  
Einrichtungen GmbH  
Neuer Hohdammweg 1  
77797 Ohlsbach  
Germany

WTO Inc.  
13900-F South Lakes Dr.  
Charlotte, NC 28273  
USA

WTO Asia  
WTO Precision Tool Holders  
(Shanghai) Co. Ltd.  
Room 109-110, Building 2  
No. 228 Banting Road  
Jiuting Town,  
Songjiang District  
201615 Shanghai  
China

## Our distribution partners. Competence right there.

**Australia**  
Dimac Tooling Ltd.  
sales@dimac.com.au

**France, east**  
Christophe Archambault  
alm@wto.de

**Japan**  
NK Works Co. Ltd.  
k\_samba@nk-works.co.jp

**Slovakia**  
ALBA precision s.r.o.  
albabprecision@albabprecision.sk

**Brazil**  
TF2  
tfdois@tfdois.com.br

**France, west**  
Christophe Archambault  
car@wto.de

**Korea**  
WTO Office Korea  
is.chon@wto-korea.com

**Spain**  
ITALMATIC, S.A.  
italmatic@italmatic.es

**Canada**  
Mittmann Industrial Inc.  
info@mittmann.com

**Great Britain**  
Cutwel Ltd.  
sales@cutwel.net

**Mexico**  
Workholding Engineering De México  
info@wem.com.mx

**Sweden**  
Bonhron & Ewing AB  
info@bonhron-ewing.se

**China**  
Shanghai Gangde  
wtocando@yahoo.com

**Hungary**  
Prevotex Hungary Kft.  
info@prevotex.hu

**Netherlands**  
Toologic BeNeLux B.V.  
info@toologic-benelux.nl

**Switzerland**  
Utilis AG  
info@utilis.com

**Czech Republic**  
ALBA precision, spol. s.r.o.  
info@albabprecision.cz

**India**  
Ulhas Patil  
u.patil@wto-asia.com

**Norway**  
Helge Karlsen Verktøy og Maskin AS  
hkvm@hkvm.no

**Taiwan**  
Kaiko Co., Ltd.  
info@kaiko.com.tw

**Denmark**  
AVN Teknik A/S  
cjo@avn.dk

**Israel**  
E.Y.A.R. Ltd.  
boris@eyar.co.il

**Poland**  
ARCO Andrzej Rudenko  
info@arcotools.pl

**Turkey**  
MYK CNC MAKINA SAN. VE  
huseyin.tatlidil@mykcnc.com.tr

**Finland**  
Suomen Terätuonti Oy  
myynti@stt.as

**Italy**  
Prymark srl  
commerciale@prymark.it

**Romania**  
SC Elif Trading SRL  
bulent.ozkan@eliftrading.com

**Ukraine**  
„LLC“ SPA Stankopromimport  
info@phoenix-ua.com